

FC
n≈3500rpm

Centrifugal pump
Bomba centrífuga
Pompe centrifuge
Центробежный насос



DESCRIPTION/DESCRIPCIONES/DESCRIPTION/ОПИСАНИЕ

- ◆ FANCY new design centrifugal pump with patent.
- ◆ The series models with standards certified CE and EAC.
- ◆ Company with management system certified ISO 9001.

- ◆ FANCY bomba centrífuga de nuevo diseño con patente.
- ◆ Los modelos de la serie con estándares certificados CE y EAC.
- ◆ Empresa con sistema de gestión certificado ISO 9001.

- ◆ Pompe centrifuge FANCY de nouvelle conception avec brevet.
- ◆ Les modèles de série aux normes certifiées CE et EAC.
- ◆ Entreprise avec système de management certifié ISO 9001.

- ◆ Центробежный насос FANCY, запатентованный.
- ◆ Модели этой серии сертифицированы по стандартам CE и EAC.
- ◆ Компания с системой менеджмента ISO 9001.

APPLICATIONS/APLICACIONES/APPLICATIONS/ПРИЛОЖЕНИЯ

- ◆ Registered design: patent n°. ZL202330191629.9
- ◆ Liquid temperature between -10°C and +80°C
- ◆ Ambient temperature between 0°C and +40°C

- ◆ Diseño registrado: patente n°. ZL202330191629.9
- ◆ Temperatura del líquido entre -10 °C y +80 °C
- ◆ Temperatura ambiente entre 0 °C y +40 °C

- ◆ Désign registre: brevet n°. ZL202330191629.9
- ◆ Température du liquide entre -10°C et +80°C
- ◆ Température ambiante entre 0°C et +40°C

- ◆ Зарегистрирован дизайн: патент №. ZL202330191629.9
- ◆ Температура жидкости от -10°C до +80°C.
- ◆ Температура окружающей среды от 0°C до +40°C.

MATERIAL DESCRIPTION/DESCRIPCIÓN MATERIAL/DESCRIPTION MATÉRIEL/ОПИСАНИЕ МАТЕРИАЛА

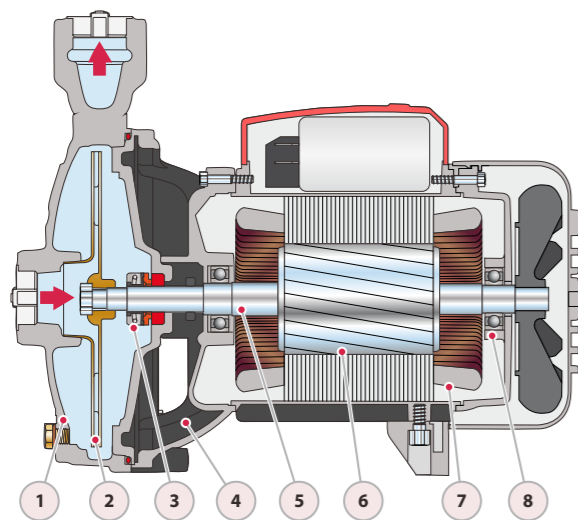

No.	Description/Descripción Description/Описание	Material/Material Matériel/Материал
1	Pump Case/Cuerpo Boîtier/Корпус насоса	Cast iron/Fundición Fonte/Чугун
2	Impeller/Impulsor Roue/Импульсор	SUS304/Inox304 Inox304/СУС304
3	Seal/Cierre Garniture/Тюлень	Ceramic&Carbon/Cerámica&Grafito Ceramic&Carbon/Керамика&Углерод
4	Connection/Conexión Lien/Связь	Cast iron/Fundición Fonte/Чугун
5	Shaft/Eje Arbre/Вал	SUS304/Inox304 Inox304/СУС304
6	Rotor/Rotor Rotor/Ротор	Silicon Steel/Acero al Silicio Acier silicium/Кремниевая сталь
7	Wiring/Alambrado Câblage/Электропроводка	100% copper/100% cobre 100% cuivre/100% медь
8	Bearing/Cojinete Palier/Подшипник	Ball bearing/Bola rodamiento Roulement bille/Шарикоподшипник

TECHNICAL DATA/DATOS TÉCNICOS/DONNÉES TECHNIQUES/ТЕХНИЧЕСКИЕ ДАННЫЕ

60Hz n≈3500l/min

MODEL MODELO MODÈLE МОДЕЛЬ	DN	Power Potencia Puissance Мощность	GPM m³/h l/min	Q=Delivery/Caudal/Débit/Поддача													
				5.3	13.2	23.8	31.7	37.0	42.3	50.2	59.5	66.1	79.3	84.6			
1-ph	3-ph	mm	kw	hp	Brass	20	18.5	15	8	-	-	-	-	-	-	-	-
FCm100	FC100	25x25	0.25	0.33	Brass	20	18.5	15	8	-	-	-	-	-	-	-	-
FCm130	FC130	25x25	0.37	0.5	Brass	23	21.5	17	8.5	-	-	-	-	-	-	-	-
FCm146	FC146	25x25	0.6	0.8	Brass	29	26.5	22	15.5	10	-	-	-	-	-	-	-
FCm158	FC158	25x25	0.75	1	Brass	34	32	27	19	11	-	-	-	-	-	-	-
FCm170	FC170	25x25	1.1	1.5	Brass	40	38	34	27.5	20.5	15	-	-	-	-	-	-
FCm170M	FC170M	32x25	1.1	1.5	Brass	37	35.5	32	26	20.5	16	10.5	-	-	-	-	-
FCm25/160B	FC25/160B	40x25	1.1	1.5	Brass	32	31.5	29.5	25	20.5	17	13	7	-	-	-	-
FCm25/160A	FC25/160A	40x25	1.5	2	Brass	40	38.5	35	30	26	23	19.5	14	6.5	-	-	-
FCm40/160B	FC40/160B	50x40	1.1	1.5	Brass	30	29.5	28	26	24	23	21	19	15	12	3	-
FCm40/160A	FC40/160A	50x40	1.5	2	Brass	32	31.5	31	29	27.5	26	24.5	22	18	14.5	6.5	2.5

PERFORMANCE/RENDIMENTO/PERFORMANCE/КРИВАЯ ПРОИЗВОДИТЕЛЬНОСТИ

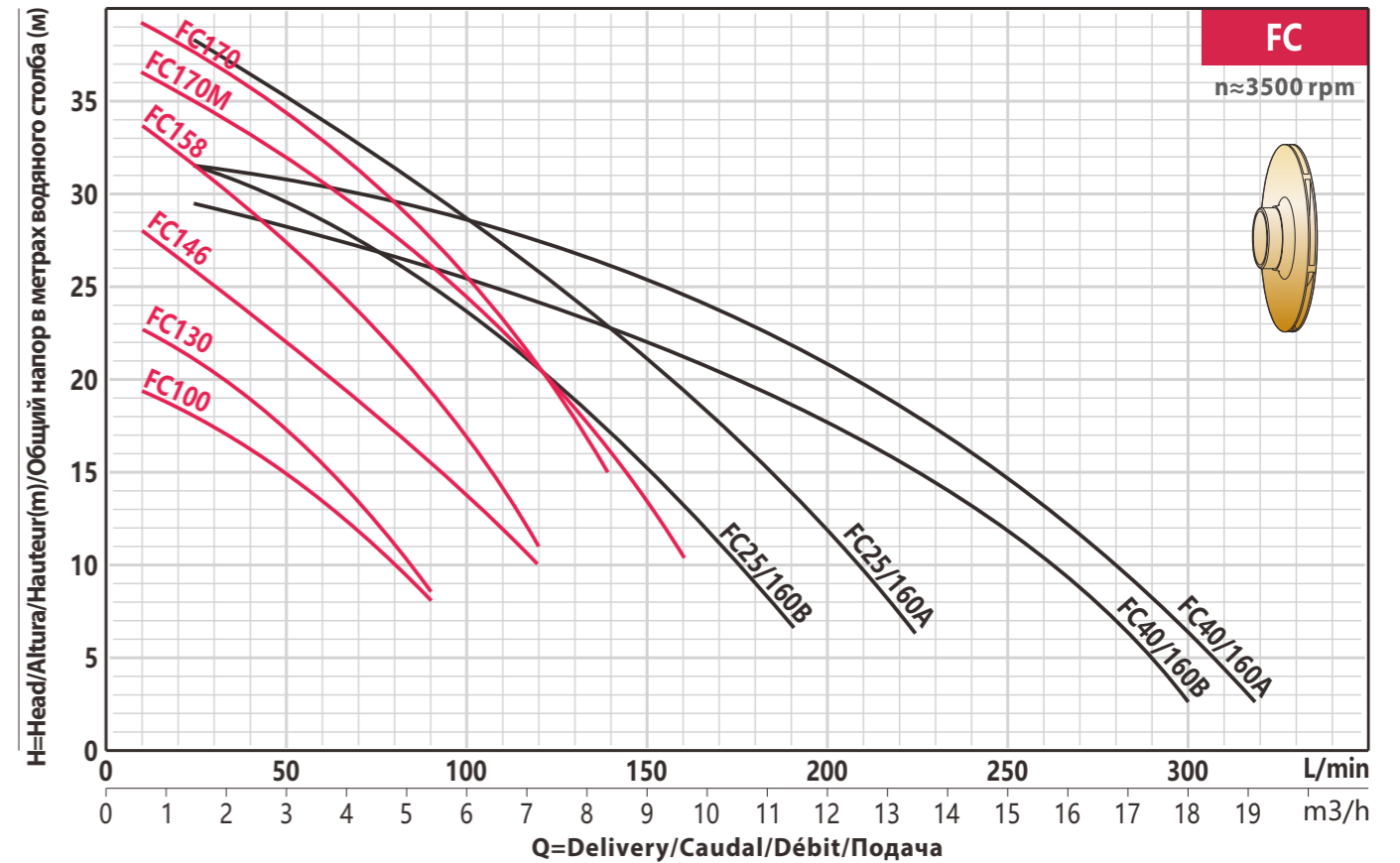

DIMENSIONS AND N.W./DIMENSIONES Y PESOS/DIMENSIONS ET POIDS/РАЗМЕРЫ И ВЕС

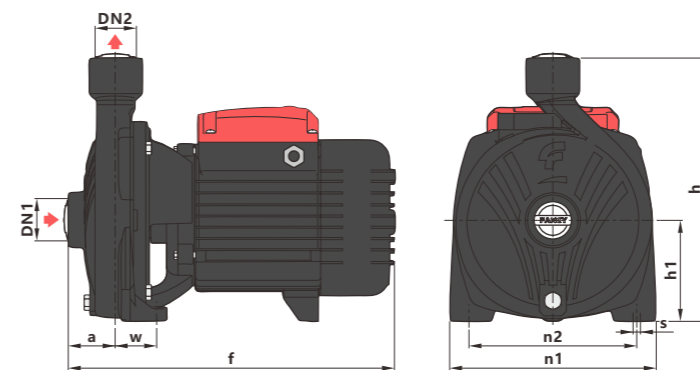

MODEL MODELO MODÈLE МОДЕЛЬ	DIMENSIONS/DIMENSIONES DIMENSIONS/РАЗМЕРЫ										GW Kg
	DN1	DN2	a	f	w	s	h	h1	n1	n2	
FC100	25	25	40	272	35	ø10.5	210	86	167	127	8
FC130	25	25	40	272	35	ø10.5	210	86	167	127	9
FC146	25	25	44	302	39	ø9	242	76	188	152	13
FC158	25	25	44	302	39	ø9	242	76	188	152	14
FC170	25	25	52	371	28	ø10	260	107	206	148	22
FC170M	32	25	52	371	28	ø10	260	107	206	148	22
FC25/160B	40	25	56	375	32	ø10	260	107	206	148	22
FC25/160A	40	25	56	375	32	ø10	260	107	206	148	24
FC40/160B	50	40	56	376	32	ø10	266	107	206	148	22
FC40/160A	50	40	56	376	32	ø10	266	107	206	148	24