

F2C

n≈2900rpm

Double impeller centrifugal pump
Bomba centrífuga doble impulsor
Pompe centrifuge à double roue
Двухколесный центробежный насос



DESCRIPTION/DESCRIPCIONES/DESCRIPTION/ОПИСАНИЕ

- ✦ FANCY new design double impeller centrifugal pump.
 - ✦ The series models with standards certified CE and EAC.
 - ✦ Company with management system certified ISO 9001.
- ✦ FANCY bomba centrífuga de doble impulsor de nuevo diseño.
 - ✦ Los modelos de la serie con estándares certificados CE y EAC.
 - ✦ Empresa con sistema de gestión certificado ISO 9001.
- ✦ Pompe centrifuge à double turbine FANCY de nouvelle conception.
 - ✦ Les modèles de série aux normes certifiées CE et EAC.
 - ✦ Entreprise avec système de management certifié ISO 9001.
- ✦ Насос с двойной крыльчаткой новой конструкции FANCY.
 - ✦ Модели этой серии сертифицированы по стандартам CE и EAC.
 - ✦ Компания с системой менеджмента ISO 9001.

APPLICATIONS/APLICACIONES/APPLICATIONS/ПРИЛОЖЕНИЯ

- ✦ Liquid temperature between -10°C and +80°C
 - ✦ Ambient temperature between 0°C and +40°C
 - ✦ Max. working pressure 10 bar
- ✦ Temperatura del líquido de -10 °C hasta +80 °C
 - ✦ Temperatura ambiente de 0 °C hasta +40 °C
 - ✦ Presión máxima en el cuerpo de la bomba 10 bar
- ✦ Température du liquide entre -10 °C et +80 °C
 - ✦ Température ambiante entre 0 °C et +40 °C
 - ✦ Max. pression de service 10 bar
- ✦ Температура жидкости от -10°C до +80°C
 - ✦ Температура окружающей среды от 0°C до +40°C
 - ✦ Макс. рабочее давление 10 бар

MATERIAL DESCRIPTION/DESCRIPCIÓN MATERIAL/DESCRIPTION MATÉRIEL/ОПИСАНИЕ МАТЕРИАЛА

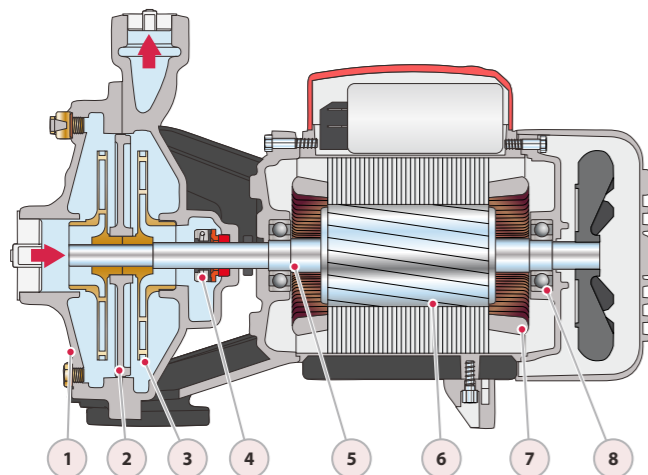

No.	Description/Descripción Description/Описание	Material/Material Matériel/Материал
1	Pump Case/Cuerpo Boîtier/Корпус насоса	Cast iron/Fundición Fonte/Чугун
2	Diffuser/Difusor Diffuseur/Диффузор	Cast iron/Fundición Fonte/Чугун
3	Impeller/Impulsor Roue/Импульсор	SUS304/Inox304 Inox304/СУС304
4	Seal/Cierre Garniture/Тюлень	Ceramic&Carbon/Cerámica&Grafito Ceramic&Carbon/Керамика&Углерод
5	Shaft/Eje Arbre/Вал	SUS304/Inox304 Inox304/СУС304
6	Rotor/Rotor Rotor/Ротор	Silicon Steel/Acero al Silicio Acier silicium/Кремниевая сталь
7	Wiring/Alambrado Câblage/Электропроводка	100% copper/100% cobre 100% cuivre/100% медь
8	Bearing/Cojinete Palier/Подшипник	Ball bearing/Bola rodamiento Roulement bille/Шарикоподшипник

TECHNICAL DATA/DATOS TÉCNICOS/DONNÉES TECHNIQUES/ТЕХНИЧЕСКИЕ ДАННЫЕ

50Hz n≈2900l/min

MODEL MODELO MODÈLE МОДЕЛЬ	DN	Power Potencia Puissance Мощность	GPM 0 m³/h 0 l/min 0	Q=Delivery/Caudal/Débit/Подача													
				2.6	7.9	13.2	19.8	26.4	37.0	39.6	42.3	44.9	47.6	55.5			
1-ph	3-ph	mm	kw	hp	Brass	46	45	42	39	34	29	19	16	12	-	-	-
F2Cm25/135	F2C25/135	40x25	1.1	1.5	Brass	46	45	42	39	34	29	19	16	12	-	-	-
F2Cm25/140M	F2C25/140M	40x25	1.5	2	Brass	50	49	46	42	38	33	24	22	19	16	14	-
F2Cm160/160	F2C160/160	32x25	1.5	2	Brass	52.5	52	48	44	37	30	11	-	-	-	-	-
F2Cm25/160B	F2C25/160B	40x25	1.5	2	Brass	52.5	52	49	46	41	34	18	12	-	-	-	-
F2Cm32/160B	F2C32/160B	40x32	1.5	2	Brass	52.5	52	48	45	41	36	28	25	22	-	-	-
F2Cm32/160A	F2C32/160A	40x32	2.2	3	Brass	61	60	58	55	50	45	34	30	25	20	-	-
F2Cm25/160A	F2C25/160A	40x25	2.2	3	Brass	61	60	58	55	50	45	34	30	25	20	-	-
F2Cm32/200C	F2C32/200C	40x32	3	4	Brass	66	65	62	59	56	52	44	42	40	38	36	30

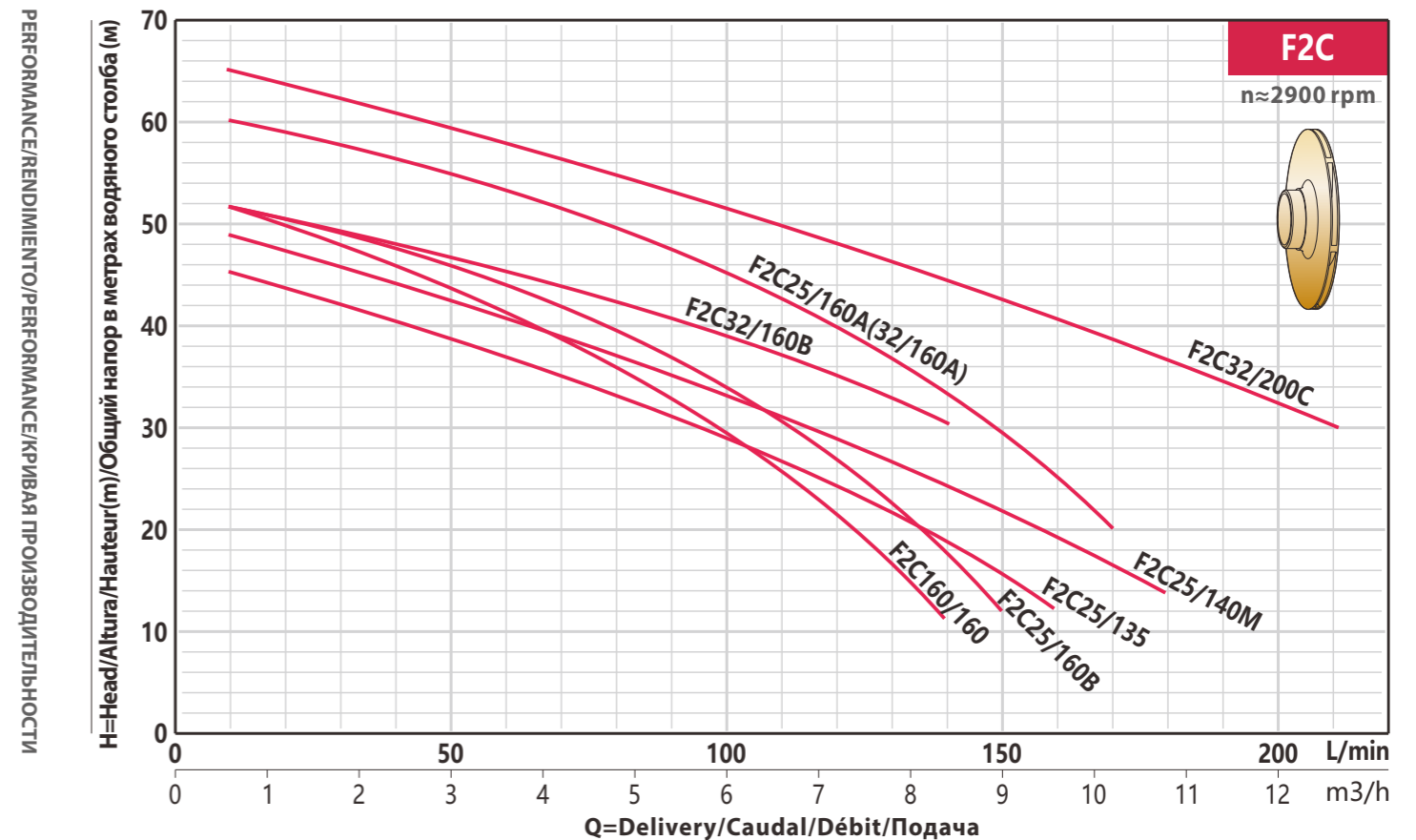

DIMENSIONS AND N.W./DIMENSIONES Y PESOS/DIMENSIONS ET POIDS/РАЗМЕРЫ И ВЕС

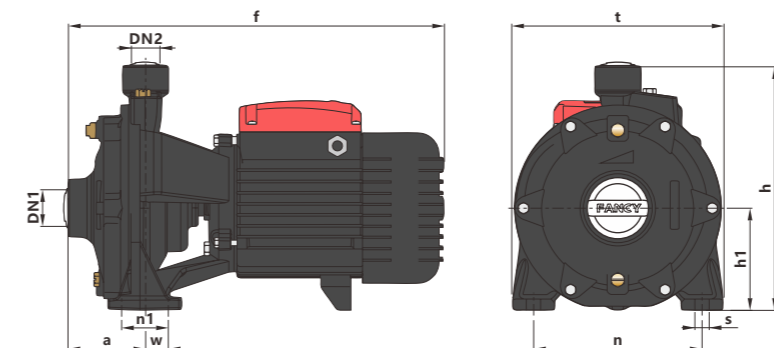

MODEL MODELO MODÈLE МОДЕЛЬ	DN1	DN2	a	f	w	s	h	h1	n	n1	t	GW Kg
F2C25/135	40	25	77	382	35	10.5	225	95	164	35	200	23
F2C25/140M	40	25	77	382	35	10.5	225	95	164	35	200	25
F2C160/160	32	25	85	413	32	10.5	268	109	185	64	231	29
F2C25/160B	40	25	85	413	32	10.5	268	109	185	64	231	29
F2C32/160B	40	32	85	413	32	10.5	268	109	185	64	231	29
F2C32/160A	40	32	85	464	32	11.5	269	112	185	64	231	36
F2C25/160A	40	25	85	464	32	11.5	269	112	185	64	231	36
F2C32/200C	40	32	85	464	32	11.5	269	112	185	64	231	39