

FZ
n≈3500rpm

Stainless steel standard pump
Bomba normalizada inox304
Pompe standard inox304
Стандартный насос SS304

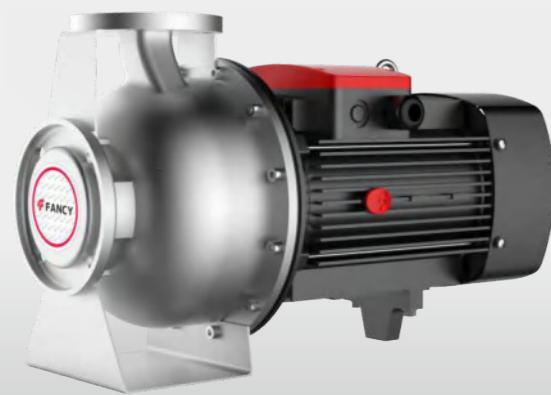

FZ

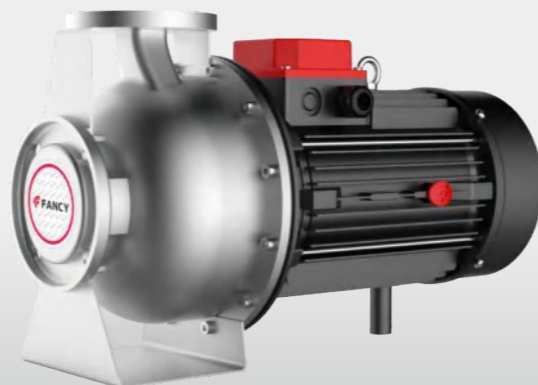

FZ(B)

DESCRIPTION/DESCRIPCIONES/DESCRIPTION/ОПИСАНИЕ

- 🇨🇷 ♦ Stainless steel 304 standard pump design.
 ♦ All wetted parts are in stainless steel 304.
 ♦ Both square motor & round motor available.
 ♦ Stainless steel AISI 316 material as request.
 ♦ Back pull-out design without removing the pipes.
 ♦ Quality bearing, wear resistance mechanical seal.
 ♦ Available to delivery some impure liquid.
 ♦ Ensuring durability and easy in operation.
- 🇪🇸 ♦ Diseño de bomba estándar de acero inoxidable 304.
 ♦ Todas las partes húmedas son de acero inoxidable 304.
 ♦ Motor cuadrado y motor redondo disponibles.
 ♦ Material de acero inoxidable 316 según pedido.
 ♦ Diseño de extracción posterior sin quitar las tuberías.
 ♦ Rodamiento de calidad y cierre mecánico personalizado.
 ♦ Disponible para la entrega de algún líquido impuro.
 ♦ Garantizar la durabilidad y fácil en la operación.
- 🇫🇷 ♦ Conception de pompe standard en acier inoxydable 304.
 ♦ Toutes les pièces en contact avec le fluide sont en inox304.
 ♦ Moteur carré et moteur rond disponibles.
 ♦ Matériau en acier inoxydable 316 comme demande.
 ♦ Conception arrière coulissante sans retirer les tuyaux.
 ♦ Roulement qualité, joint mécanique de résistance à l'usure.
 ♦ Disponible pour la livraison de liquide impur.
 ♦ Assurer la durabilité et la facilité d'utilisation.
- 🇷🇺 ♦ Стандартная конструкция насоса из нержавеющей стали 304.
 ♦ Все смачиваемые детали изготовлены из нержавеющей стали 304.
 ♦ Доступен как квадратный, так и круглый двигатель.
 ♦ Нержавеющая сталь AISI 316 по запросу.
 ♦ Выдвижная конструкция без снятия труб.
 ♦ Качественный подшипник, износостойкое механическое уплотнение.
 ♦ Возможна доставка нечистой жидкости.
 ♦ Обеспечение долговечности и простоты в эксплуатации.

USING/UTILIZACIÓN/UTILISATION/ИСПОЛЬЗОВАНИЕ

- 🇨🇷 ♦ Liquid temperature between -10°C and +120°C
 ♦ Ambient temperature between 0°C and +50°C
 ♦ Max. working pressure 16 bar
- 🇪🇸 ♦ Temperatura del líquido de -10 °C hasta +120 °C
 ♦ Temperatura ambiente de 0 °C hasta +50 °C
 ♦ Presión máxima en el cuerpo de la bomba 16 bar
- 🇫🇷 ♦ Température du liquide entre -10 °C et +120 °C
 ♦ Température ambiante entre 0 °C et +50 °C
 ♦ Max. pression de service 16 bar
- 🇷🇺 ♦ Температура жидкости от -10°C до +120°C
 ♦ Температура окружающей среды от 0°C до +50°C
 ♦ Макс. рабочее давление 16 бар

MODEL CODE/CÓDIGO MODELO/COE MODÈLE/КОД МОДЕЛИ

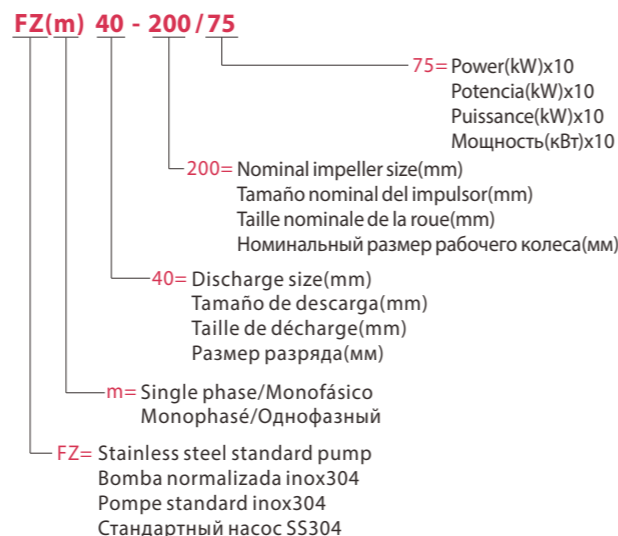

TECHNICAL DATA/DATOS TÉCNICOS/DONNÉES TECHNIQUES/ТЕХНИЧЕСКИЕ ДАННЫЕ

60Hz n≈3500l/min

MODEL MODELO MODÈLE МОДЕЛЬ	DN	Power Potencia Puissance Мощность		380V Amp.	Q=Delivery/Caudal/Débit/Подача																				
		kw	hp		GPM	0	40	53	79	88	106	159	185	238	317	502	555	581	608	661	899	952	1004	1057	
1-ph	3-ph	mm			l/min	0	9	12	18	20	24	36	42	54	72	114	126	132	138	150	204	216	228	240	
					H=Head(m)/Altura(m)/Hauteur(m)/Общий напор в метрах водяного столба (м)																				
FZm32-160/11	FZ32-160/11	50x32	1.1	1.5	2.4	22.5	19.9	18.4	14.1	12	-	-	-	-	-	-	-	-	-	-	-	-	-	-	-
FZm32-160/15	FZ32-160/15	50x32	1.5	2	3.2	29.5	26.5	24.5	19.2	17	-	-	-	-	-	-	-	-	-	-	-	-	-	-	-
FZm32-160/22	FZ32-160/22	50x32	2.2	3	4.6	37	34	32	27	25	-	-	-	-	-	-	-	-	-	-	-	-	-	-	-
FZm32-200/30	FZ32-200/30	50x32	3	4	6	44	40	37.5	31	28	-	-	-	-	-	-	-	-	-	-	-	-	-	-	-
FZm32-200/40	FZ32-200/40	50x32	4	5.5	7.8	55	52	49.5	43.5	40.5	37	-	-	-	-	-	-	-	-	-	-	-	-	-	-
-	FZ32-200/55	50x32	5.5	7.5	10.6	70.5	67.5	65	58.5	55	51	-	-	-	-	-	-	-	-	-	-	-	-	-	-
FZm40-125/15	FZ40-125/15	65x40	1.5	2	3.2	20	-	19	17.6	17	15.7	10.3	7	-	-	-	-	-	-	-	-	-	-	-	-
FZm40-125/22	FZ40-125/22	65x40	2.2	3	4.6	26.5	-	25.5	24	23.5	22	16.4	13	-	-	-	-	-	-	-	-	-	-	-	-
FZm40-160/30	FZ40-160/30	65x40	3	4	6	31	-	29.5	27.5	27	25.5	20	17	-	-	-	-	-	-	-	-	-	-	-	-
FZm40-160/40	FZ40-160/40	65x40	4	5.5	7.8	40	-	38.5	37	36	34.5	29	25.5	-	-	-	-	-	-	-	-	-	-	-	-
-	FZ40-200/55	65x40	5.5	7.5	10.6	47	-	45.5	44	43	41	35	31	-	-	-	-	-	-	-	-	-	-	-	-
-	FZ40-200/75	65x40	7.5	10	14.4	58	-	57	55.5	55	53.5	47.5	44	-	-	-	-	-	-	-	-	-	-	-	-
-	FZ40-200/110	65x40	11	15	20.6	72	-	71	70	70	68.5	63	59	-	-	-	-	-	-	-	-	-	-	-	-
FZm50-125/22	FZ50-125/22	65x50	2.2	3	4.6	19	-	-	-	-	17.5	14.9	13.4	10.7	-	-	-	-	-	-	-	-	-	-	-
FZm50-125/30	FZ50-125/30	65x50	3	4	6	22	-	-	-	-	20.5	18.4	17	14.4	8	-	-	-	-	-	-	-	-	-	-
FZm50-125/40	FZ50-125/40	65x50	4	5.5	7.8	26.5	-	-	-	-	26	24	22.5	20.5	14	-	-	-	-	-	-	-	-	-	-
-	FZ50-160/55	65x50	5.5	7.5	10.6	33	-	-	-	-	31	28.5	27	24.5	18	-	-	-	-	-	-	-	-	-	-
-	FZ50-160/75	65x50	7.5	10	14.4	40	-	-	-	-	38.5	36	35	32.5	26	-	-	-	-	-	-	-	-	-	-
-	FZ50-200/92	65x50	9.2	12.5	17.6	53	-	-	-	-	49	47.5	44.5	34	-	-	-	-	-	-	-	-	-	-	-
-	FZ50-200/110	65x50	11	15	20.6	59	-	-	-	-	55	54	51	42	-	-	-	-	-	-	-	-	-	-	-
-	FZ50-200/150	65x50	15	20	27.9	72	-	-	-	-	69	68	65	57	-	-	-	-	-	-	-	-	-	-	-
FZm65-125/40	FZ65-125/40	80x65	4	5.5	7.8	22.2	-	-	-	-	19.8	19	17.3	13.5	6.3	-	-	-	-	-	-	-	-	-	-
-	FZ65-125/55	80x65	5.5	7.5	10.6	27	-	-	-	-	24	22.2	18.5	10.8	8	-	-	-	-	-	-	-	-	-	-
-	FZ65-125/75	80x65	7.5	10	14.4	32	-	-	-	-	29.5	27.8	24	16.1	13.4	12	-	-	-	-	-	-	-	-	-
-	FZ65-160/92	80x65	9.2	12.5	17.6	36.5	-	-	-	-	34.5	32.8	29	21.1	18.3	16.8	-	-	-	-	-	-	-	-	-
-	FZ65-160/110	80x65	11	15	20.6	40.5	-	-	-	-	38.5	37.1	33.5	25.8	23	21.5	20	-	-	-	-	-	-	-	-
-	FZ65-160/150	80x65	15	20	27.9	48	-	-	-	-	45.5	44	40.5	32.6	29.6	28	26.5	-	-	-	-	-	-	-	-
-	FZ65-200/150	80x65	15	20	27.9	53.5	-	-	-	-	51	49	44.5	35.3	31.8	30	-	-	-	-	-	-	-	-	-
-	FZ65-200/185	80x65	18.5	25	34.2	60.5	-	-	-	-	58.5	56.5	52	43	39.7	38	36.3	-	-	-	-	-	-	-	-
-	FZ65-200/220	80x65	22	30	40.5	67	-	-	-	-	65.5	64	60	51	48	46.5	45	-	-	-	-	-	-	-	-
-	FZ80-160/110	100x80	11	15	20.6	29	-	-	-	-	-	-	-	27.5	24.2	23	22.4	21.8	20.4	12.5	-	-	-	-	-
-	FZ80-160/150	100x80	15	20	27.9	35	-	-	-	-	-	-	-	34.5	31.5	30.5	30	29.4	28.1	21	19.1	17	-	-	-
-	FZ80-160/185	100x80	18.5	25	34.2	40	-	-	-	-	-	-	-	39.5	36.7	35.7	35.2	34.7	33.5	26.4	24.4	22.3	20	-	-
-	FZ80-200/220	100x80	22	30	40.5	50	-	-	-	-	-	-	-	48.5	44.5	43	42	41	39	27.8	25	-	-	-	-
-	FZ80-200/300	100x80	30	40	54.9	60	-	-	-	-	-	-	-	59	56	54.5	54	53	51	41.5	39	36.1	33	-	-
-	FZ80-200/370	100x80	37	50	67.4	66	-	-	-	-	-	-	-	64	61	59.5	59	58	56.5	47	44.5	41.5	38.5	-	-

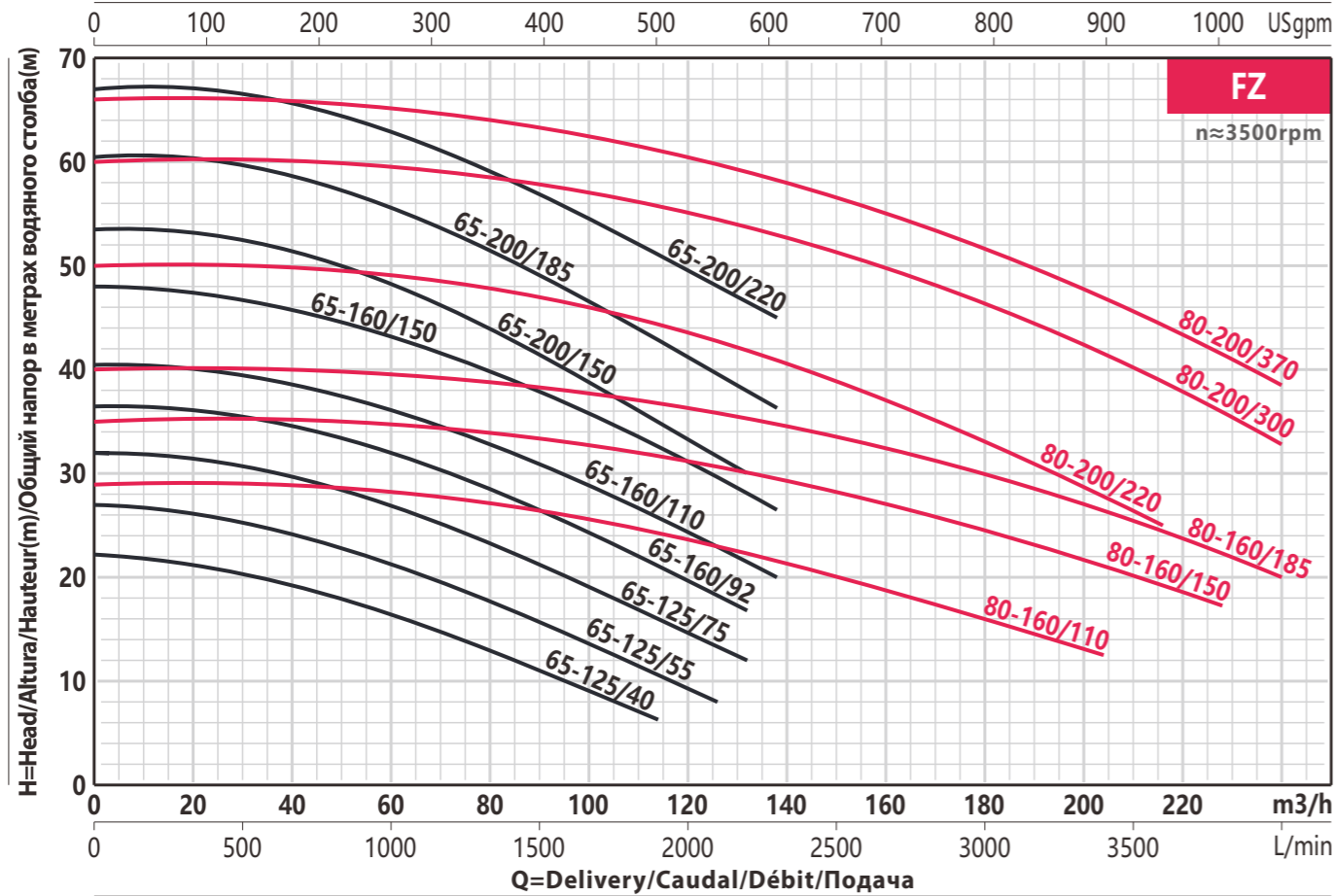
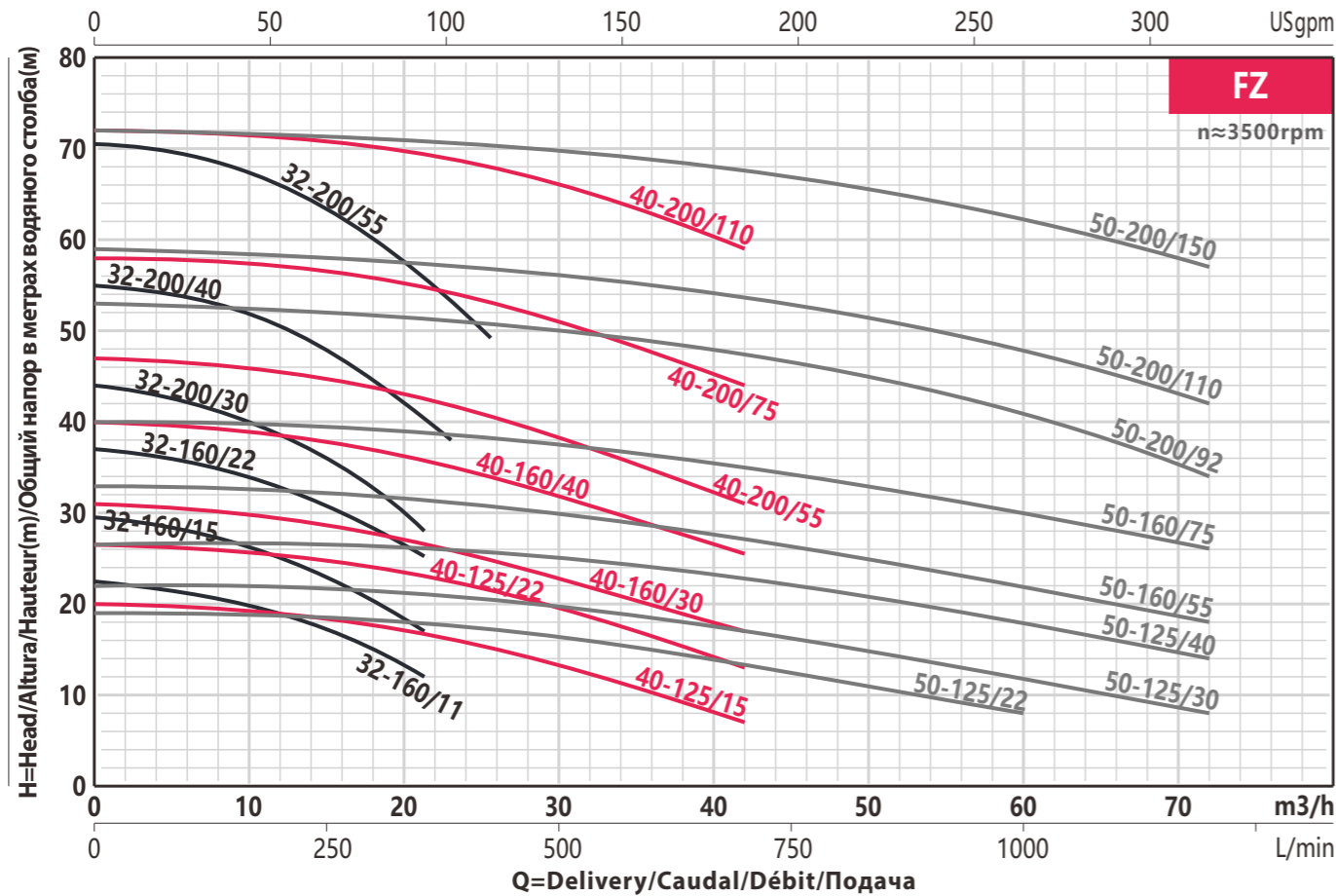

MATERIAL/MATERIAL/MATÉRIEL/MАТЕРИАЛ

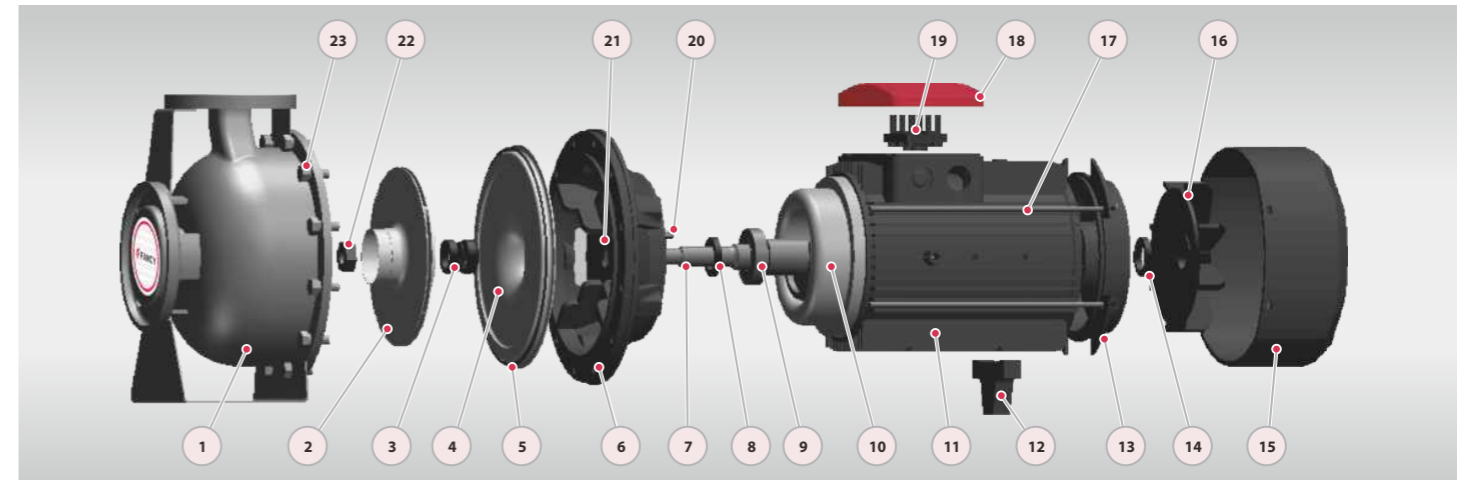

No.	Description/Descripción Description/Описание	Material/Material Matériel/Mатериал	No.	Description/Descripción Description/Описание	Material/Material Matériel/Mатериал	No.	Description/Descripción Description/Описание	Material/Material Matériel/Mатериал
1	Pump Case/Cuerpo Boitier/Корпус насоса	SUS304/Inox304 Inox304/СУС304	9	Bearing/Cojinete Palier/Подшипник	Ball bearing/Bolarodamiento Roulement bille Шарикоподшипник	17	Bolt/Perno Boulon/болт	Steel/Acero Acier/Сталь
2	Impeller/Impulsor Roue/Импульсор	SUS304/Inox304 Inox304/СУС304	10	Wiring/Alambrado Câblage/ Электропроводка	100% copper/100% cobre 100% cuivre/100% медь	18	Terminal Box/Caja Bornas Boîte Bornes/Терминал	Aluminum/Aluminio Aluminium/Алюминий
3	Seal/Cierre Garniture/Тюлень	SiC&Carbon/SiC&Grafito SiC&Carbon/SiC&Углерод	11	Motor Case/Cuerpo Motor /Boitier Moteur /Корпус двигателя	Aluminum/Aluminio Aluminium/Алюминий	19	Terminal Board/Tablero Bornas Bornier/Клемная колодка	Plastic/Plástico Plastique/Пластик
4	Baffle plate/Placa baffle Plaque chicane/ Перегородка	SUS304/Inox304 Inox304/СУС304	12	Support Foot/Soporte Pie Pied support/ Опорная нога	Plastic/Plástico Plastique/Пластик	20	Impeller Key/Chaveta Clé/Шпонка крыльчатки	Iron/Hierro Le fer/Железо
5	O-ring/Junta Tórica Joint torique/ Хунта Торика	Rubber/Caucho Caoutchouc/Резина	13	Back Cover/Tapa Trasera Capot Arrière/ Задняя обложка	Cast iron/Fundición Fonte/Чугун	21	Deflector/Deflector Déflecteur/Дефлектор	Rubber/Caucho Caoutchouc/Резина
6	Connection/Conexión Lien/Связь	Cast iron/Fundición Fonte/Чугун	14	Reinforced Seal/ Sello/Sceller/ Усиленное уплотнение	Rubber/Caucho Caoutchouc/Резина	22	Impeller Nut/ Nuez/Noix/ Гайка рабочего колеса	Steel/Acero Acier/Сталь
7	Shaft/Eje Arbre/Вал	SUS304/Inox304 Inox304/СУС304	15	Fan Cover/ Tapa/Capot/ Крышка вентилятора	Aluminum/Aluminio Aluminium/Алюминий	23	Bolt/Perno Boulon/болт	Steel/Acero Acier/Сталь
8	Reinforced Seal/ Sello/Sceller/ Усиленное уплотнение	Rubber/Caucho Caoutchouc/Резина	16	Fan/Ventilador Ventilateur/Вентилятор	Plastic/Plástico Plastique/Пластик			

DIMENSIONS AND N.W./DIMENSIONES Y PESOS/DIMENSIONS ET POIDS/РАЗМЕРЫ И ВЕС

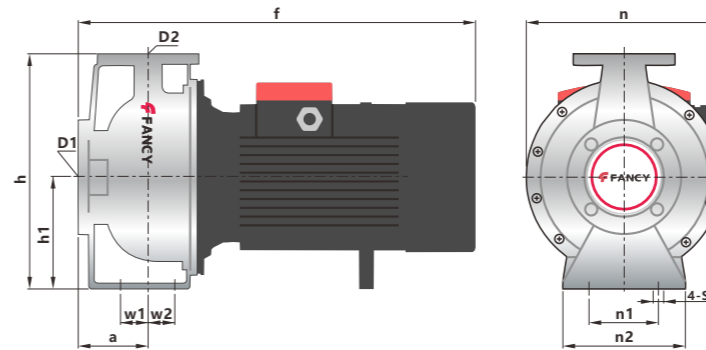

MODEL MODELO MODÈLE МОДЕЛЬ	DIMENSIONS/DIMENSIONES DIMENSIONS/РАЗМЕРЫ mm											NW Kg	
	D1	D2	a	f	h	h1	n	n1	n2	w1	w2		s
32-160/11-15	50	32	98	470	308	152	245	148	175	55	38	10	19.6/22.5
32-160/22	50	32	98	525	308	152	245	148	175	55	38	10	24.6
32-200/30-40	50	32	105	530	340	160	284	148	175	55	38	10	32.8/39.5
32-200/55	50	32	105	575	340	160	284	148	175	55	38	10	48.5
40-125/15-22	65	40	105	470	314	152	245	148	175	55	38	10	20.1/22.7
40-160/30-40	65	40	105	525	314	152	245	148	175	55	38	10	28/35.1
40-200/55-75	65	40	105	575	340	160	284	148	175	55	38	10	48.8/56.2
40-200/110	65	40	105	630	340	160	284	148	175	55	38	10	67.5
50-125/22	65	50	105	470	314	152	245	148	175	55	38	10	28.1
50-125/30-40	65	50	105	530	314	152	245	148	175	55	38	10	28.6/35.2
50-160/55-75	65	50	105	575	340	160	284	148	175	55	38	10	49.1/55.5
50-200/92-110	65	50	105	630	340	160	284	148	175	55	38	10	61.7/67.5
50-200/150	65	50	105	750	365	185	284	148	175	55	38	10	96
65-125/40	80	65	98	530	330	152	245	148	175	55	38	10	40
65-125/55-75	80	65	105	575	358	160	284	148	175	55	38	10	52/58.5
65-160/92-110	80	65	105	630	358	160	284	148	175	55	38	10	67/75.6
65-160/150	80	65	105	750	385	185	284	148	175	55	38	10	93
65-200/150-185	80	65	105	750	385	185	284	148	175	55	38	10	114/127
65-200/220	80	65	105	750	385	185	284	148	175	55	38	10	136
80-160/110	100	80	125	780	410	185	284	148	175	55	38	10	85
80-160/150-185	100	80	125	780	410	185	284	148	175	55	38	10	119/135
80-200/220	100	80	125	780	435	185	284	148	175	55	38	10	185
80-200/300-370	100	80	125	880	450	200	400	280	320	47	48	15	273/297