

IPL
n≈3500rpm



Inline circulation pump
Bomba de circulación en línea
Pompe de circulation en ligne
Встроенный циркуляционный насос

DESCRIPTION/DESCRIPCIONES/DESCRIPTION/ОПИСАНИЕ

- ◆ Single impeller inline circulation pump.
- ◆ New design noiseless, energy-saving pump.
- ◆ Compact and proportional design.
- ◆ Ensuring durability and easy in operation.
- ◆ Impeller in plastic or cast iron.
- ◆ YE3 high efficient motor, with protection IP55 class F.
- ◆ Quality bearing, wear resistance mechanical seal.
- ◆ Liquid temperature between -10°C and +120°C.

- ◆ Bomba de circulación en línea de un solo impulsor.
- ◆ Nuevo diseño bomba que silencioso y ahorra energía.
- ◆ El diseño compacto y proporcional.
- ◆ Asegurando durabilidad y fácil operación.
- ◆ Impulsor en plástico o fundición.
- ◆ Motor de alta eficiencia YE3, con protección IP55 clase F.
- ◆ Rodamiento de calidad y cierre mecánico personalizado.
- ◆ Temperatura del líquido entre -10 °C y + 120 °C.

- ◆ Pompe de circulation en ligne à une roue.
- ◆ Nouvelle conception de pompe silencieuse et économe.
- ◆ La conception compacte et proportionnelle.
- ◆ Assurer la durabilité et facile à utiliser.
- ◆ Roue en plastique ou en fonte.
- ◆ Moteur haute efficacité YE3, avec protection IP55 classe F.
- ◆ Roulement qualité, joint mécanique résistance à l'usure.
- ◆ Température du liquide entre -10°C et + 120°C.

- ◆ Циркуляционный насос с одним рабочим колесом.
- ◆ Бесшумный энергосберегающий насос новой конструкции.
- ◆ Компактный и пропорциональный дизайн.
- ◆ Обеспечение долговечности и простоты в эксплуатации.
- ◆ Рабочее колесо из пластмассы или чугуна.
- ◆ Высокоэффективный двигатель YE3 с классом защиты IP55 F.
- ◆ Качественный подшипник и механическое уплотнение.
- ◆ Температура жидкости от -10°C до +120°C.

APPLICATIONS/APLICACIONES/APPLICATIONS/ПРИЛОЖЕНИЯ

- ◆ Suitable for use with clean water and liquids that are not chemically aggressive towards the materials from which the pump is made. These pumps are widely used in domestic, irrigation, water supply, pressure boosting, HVAC circulation system etc.

- ◆ Se recomiendan para el bombeo agua limpia y líquidos no químicamente agresivos con los materiales de los que está hecha la bomba. Se utilizan en los hogares, el riego, el suministro de agua, aumento de presión, sistema de circulación HVAC etc.

- ◆ Recommandé pour une utilisation avec de l'eau propre et des liquides qui ne sont pas chimiquement agressifs envers le matériau de la pompe. Utilisées dans le ménage, l'irrigation, l'approvisionnement, surpression, système de circulation HVAC en eau.

- ◆ Подходит для использования с чистой водой и жидкостями, химически не агрессивными по отношению к материалам, из которых изготовлен насос. Эти насосы широко используются в быту, ирригации, водоснабжении, повышении давления, циркуляционной системе отопления, вентиляции и кондиционирования воздуха и т. д.

MODEL CODE/CÓDIGO MODELO/COE MODÈLE/КОД МОДЕЛИ

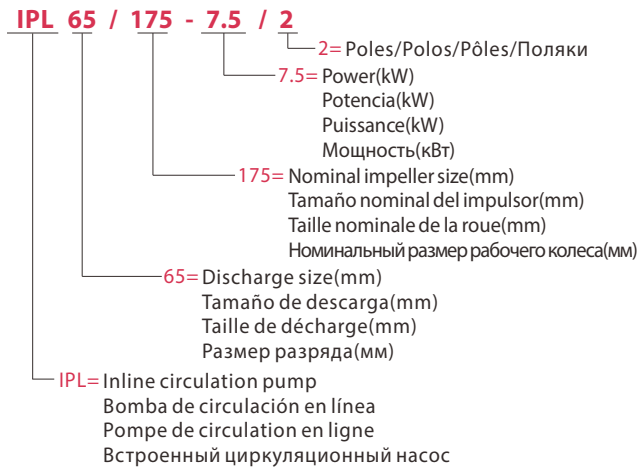

TECHNICAL DATA/DATOS TÉCNICOS/DONNÉES TECHNIQUES/ТЕХНИЧЕСКИЕ ДАННЫЕ

60Hz n≈3500l/min

MODEL MODELO MODÈLE МОДЕЛЬ	DN mm	Power Potencia Puissance Мощность		Impeller	Q=Delivery/Caudal/Débit/Подача															
		kw	hp		GPM 0	44	88	110	132	154	167	185	203	229	247	264	308			
					l/min 0	167	333	417	500	583	633	700	767	867	933	1000	1167			
3-ph					m³/h 0	10	20	25	30	35	38	42	46	52	56	60	70			
					H=Head(m)/Altura(m)/Hauteur(m)/Общий напор в метрах водяного столба (м)															
IPL40/120-1.5/2	40x40	1.5	2	PPO	18	18.2	16	13.5	10.5	6.8	-	-	-	-	-	-	-			
IPL40/130-2.2/2	40x40	2.2	3	PPO	21	22	20	18	15	12	9.7	-	-	-	-	-	-			
IPL40/150-3/2	40x40	3	4	PPO	26	26	27	25	23	20	18	15	-	-	-	-	-			
IPL40/160-4/2	40x40	4	5.5	PPO	31	31.5	30.3	29	27	24.8	22.7	20	16.5	11	-	-	-			
IPL40/175-5.5/2	40x40	5.5	7.5	Cast Iron	40	41	40	39	37.8	35.5	34	32	30	-	-	-	-			
IPL40/195-7.5/2	40x40	7.5	10	Cast Iron	51	52	50.5	49	47	44	42	-	-	-	-	-	-			
IPL50/120-1.5/2	50x50	1.5	2	PPO	15	14.8	14	13	12	10.5	9.8	8.2	6.8	-	-	-	-			
IPL50/130-2.2/2	50x50	2.2	3	PPO	19	19	18	17.2	16.2	15	14	12.9	11.2	8.8	-	-	-			
IPL50/140-3/2	50x50	3	4	PPO	22	22	21.8	21	20.2	19	18.5	17.2	16	13.5	12	-	-			
IPL50/150-4/2	50x50	4	5.5	PPO	27	27	26.2	25.9	25	24	23.5	22.4	21	18.5	16.5	-	-			
IPL50/165-5.5/2	50x50	5.5	7.5	Cast Iron	32.7	32.8	32	31.3	30.5	29.3	28.5	27.4	26	23.5	22	19.5	-			
IPL50/175-5.5/2	50x50	5.5	7.5	Cast Iron	38.5	38.3	37.8	37.2	36.8	36	-	-	-	-	-	-	-			
IPL50/175-7.5/2	50x50	7.5	10	Cast Iron	38.5	38.3	37.8	37.2	36.8	36	35.5	34.6	33.7	32	30.5	28.9	23.2			
IPL50/185-7.5/2	50x50	7.5	10	Cast Iron	42	44	44	44	43.8	43	42	41	39.5	-	-	-	-			

MODEL MODELO MODÈLE МОДЕЛЬ	DN mm	Power Potencia Puissance Мощность		Impeller	Q=Delivery/Caudal/Débit/Подача															
		kw	hp		GPM 0	132	176	220	273	308	352	374	396	419	485	529	599			
					l/min 0	500	667	833	1033	1167	1333	1417	1500	1583	1833	2000	2267			
3-ph					m³/h 0	30	40	50	62	70	80	85	90	95	110	120	136			
					H=Head(m)/Altura(m)/Hauteur(m)/Общий напор в метрах водяного столба (м)															
IPL65/115-1.5/2	65x65	1.5	2	PPO	14.4	12	9.5	5.8	-	-	-	-	-	-	-	-	-			
IPL65/110-2.2/2	65x65	2.2	3	PPO	15.5	14.6	13.3	11.5	8.5	6	-	-	-	-	-	-	-			
IPL65/120-3/2	65x65	3	4	PPO	18.3	17.5	16.7	15	12	10	7	-	-	-	-	-	-			
IPL65/130-4/2	65x65	4	5.5	PPO	21	21	20.2	18.9	16.5	14.5	11.2	9.5	8	-	-	-	-			
IPL65/145-5.5/2	65x65	5.5	7.5	Cast Iron	21.2	21.2	21	20.3	19.2	18.3	16.8	15.7	14.6	13	-	-	-			
IPL65/155-5.5/2	65x65	5.5	7.5	Cast Iron	26.5	26.9	26.7	26.1	25.5	-	-	-	-	-	-	-	-			
IPL65/155-7.5/2	65x65	7.5	10	Cast Iron	26.5	26.9	26.7	26.1	25.5	24.6	23.3	22.6	21.9	20.7	17.2	-	-			
IPL65/165-5.5/2	65x65	5.5	7.5	Cast Iron	25	25.7	25	23.5	21.5	20	17.8	16.5	-	-	-	-	-			
IPL65/175-5.5/2	65x65	5.5	7.5	Cast Iron	33	33	32.2	31	-	-	-	-	-	-	-	-	-			
IPL65/175-7.5/2	65x65	7.5	10	Cast Iron	33	33	32.2	31	29.2	28	26	24.5	23.5	-	-	-	-			
IPL80/105-3/2	80x80	3	4	PPO	14.7	13.7	13	12.4	11.2	10.5	9.2	8.5	7.9	7	4.4	-	-			
IPL80/110-4/2	80x80	4	5.5	PPO	15.6	15	14.6	14	13	12.4	11.2	10.5	10	9	6.6	4.5	-			
IPL80/120-4/2	80x80	4	5.5	PPO	17.2	16.6	16.8	15.5	14.5	13.8	12.7	12	11.2	10.3	7.8	5.6	-			
IPL80/145-5.5/2	80x80	5.5	7.5	Cast Iron	18.3	18.2	18.5	18.3	18	17.7	17.1	16.8	16.1	15.6	14	12.5	-			
IPL80/155-7.5/2	80x80	7.5	10	Cast Iron	23	22.5	22.8	22.8	22.7	22.2	22	21.6	21.1	20.8	19.3	18	16			

MATERIAL DESCRIPTION/DESCRIPCIÓN MATERIAL/DESCRIPTION MATÉRIEL/ОПИСАНИЕ МАТЕРИАЛА

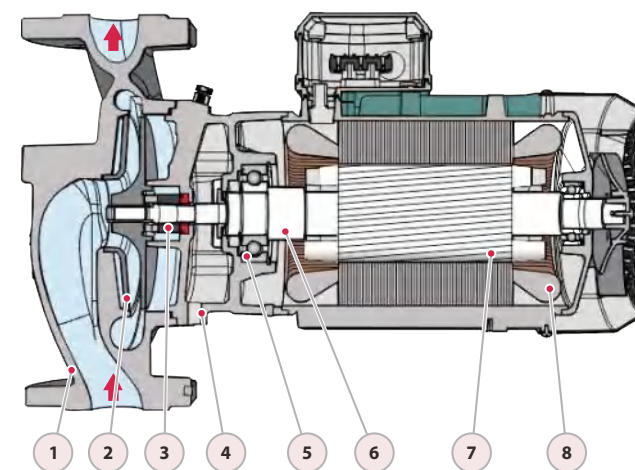

No.	Description/Descripción Description/Описание	Material/Material Matériel/Материал
1	Pump Case/Cuerpo Boitier/Корпус насоса	Cast iron/Fundición Fonte/Чугун
2	Impeller/Impulsor Roue/Импульсор	Plastic/Plástico Cast iron/Fundición Plastique/Пластик Fonte/Чугун
3	Seal/Cierre Garniture/Тюлень	SiC&Carbon/SiC&Графит SiC&Carbon/SiC&Углерод
4	Connection/Conexión Lien/Связь	Cast iron/Fundición Fonte/Чугун
5	Bearing/Cojinete Palier/Подшипник	Ball bearing/Bola rodamiento Roulement bille/Шарикоподшипник
6	Shaft/Eje Arbre/Вал	SUS304/Inox304 Inox304/CUC304
7	Rotor/Rotor Rotor/Ротор	Silicon Steel/Acero al Silicio Acier silicium/Кремниевая сталь
8	Wiring/Alambrado Câblage/Электропроводка	100% copper/100% cobre 100% cuivre/100% медь

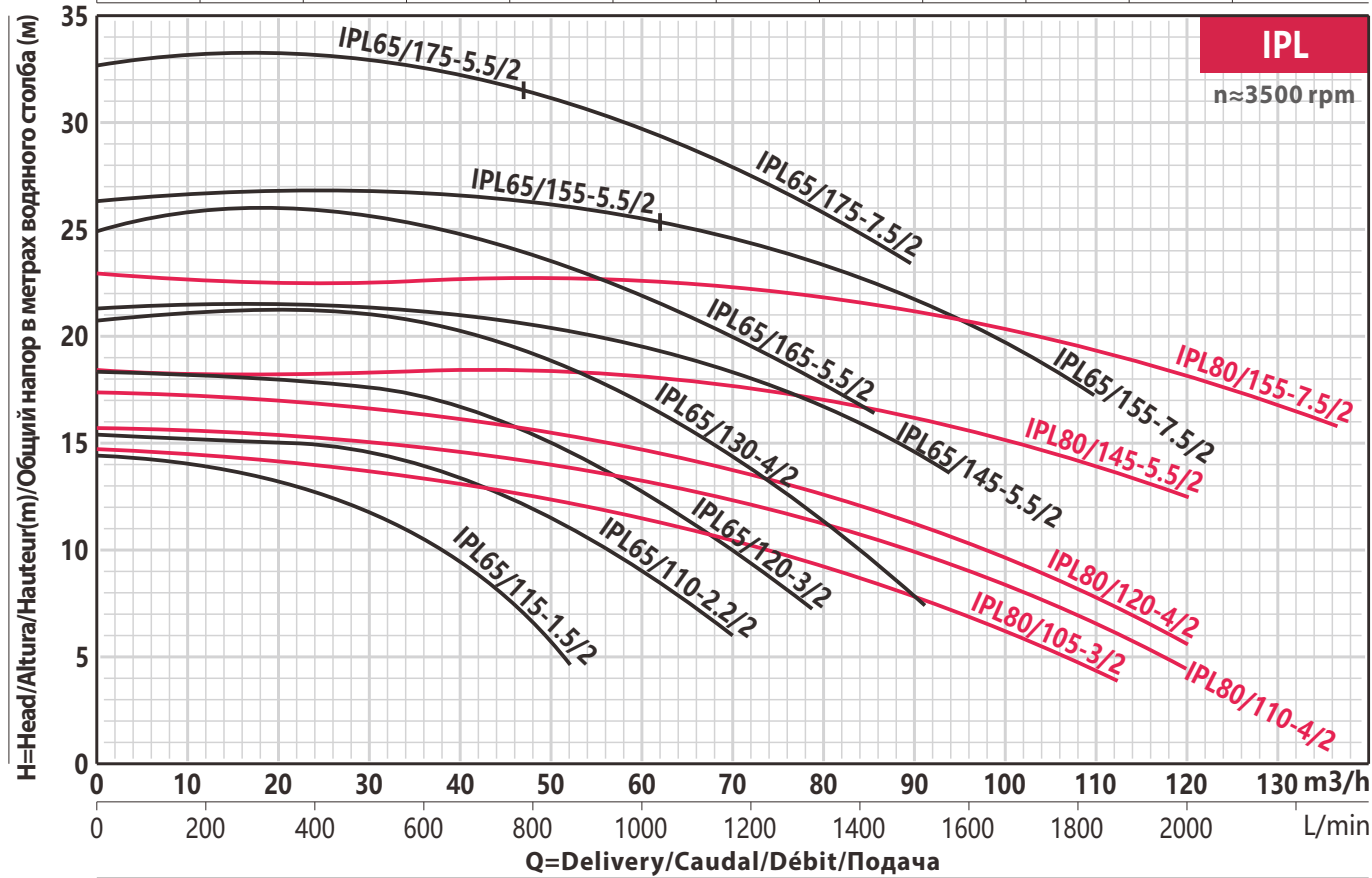
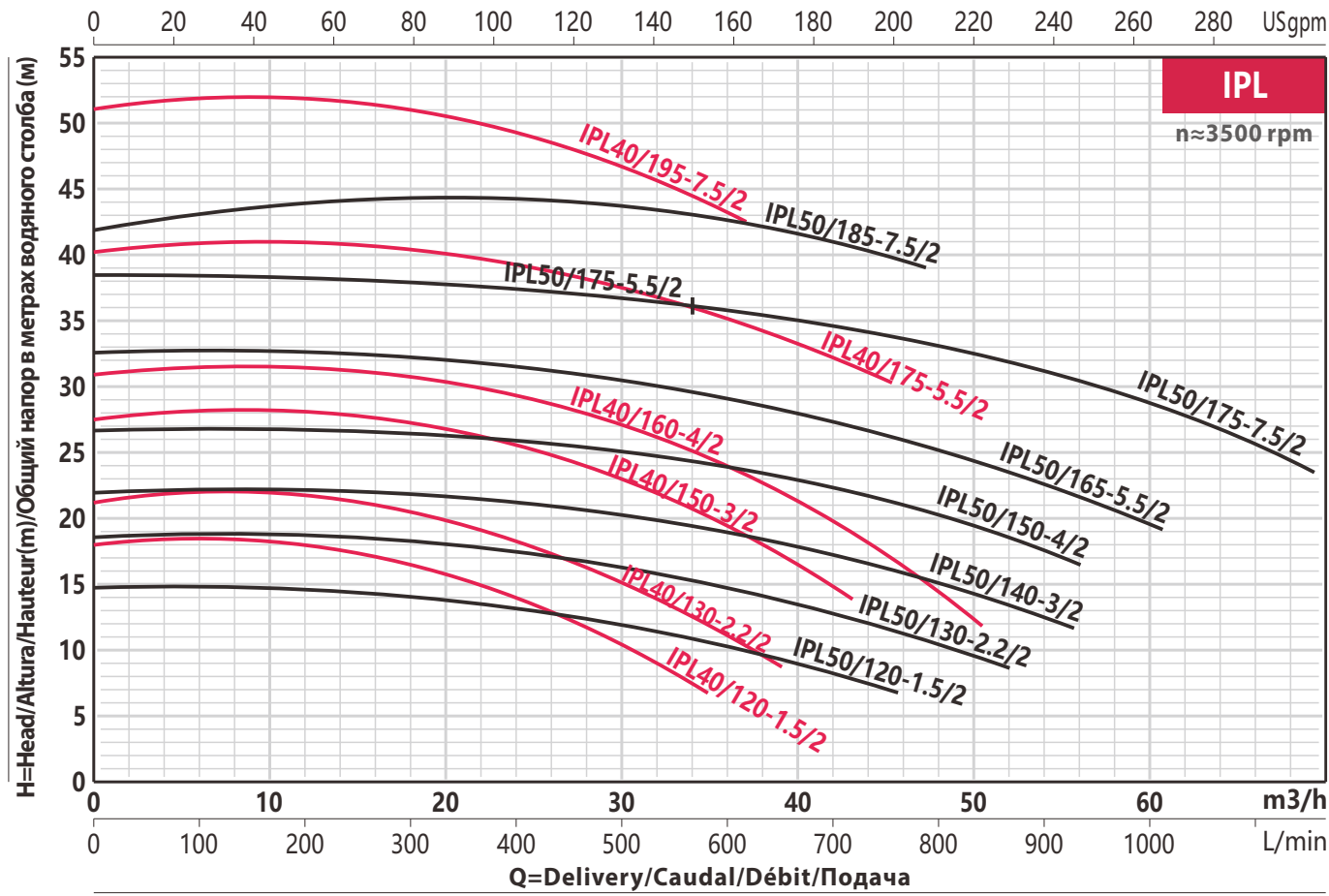

DIMENSIONS AND N.W./DIMENSIONES Y PESOS/DIMENSIONS ET POIDS/РАЗМЕРЫ И ВЕС

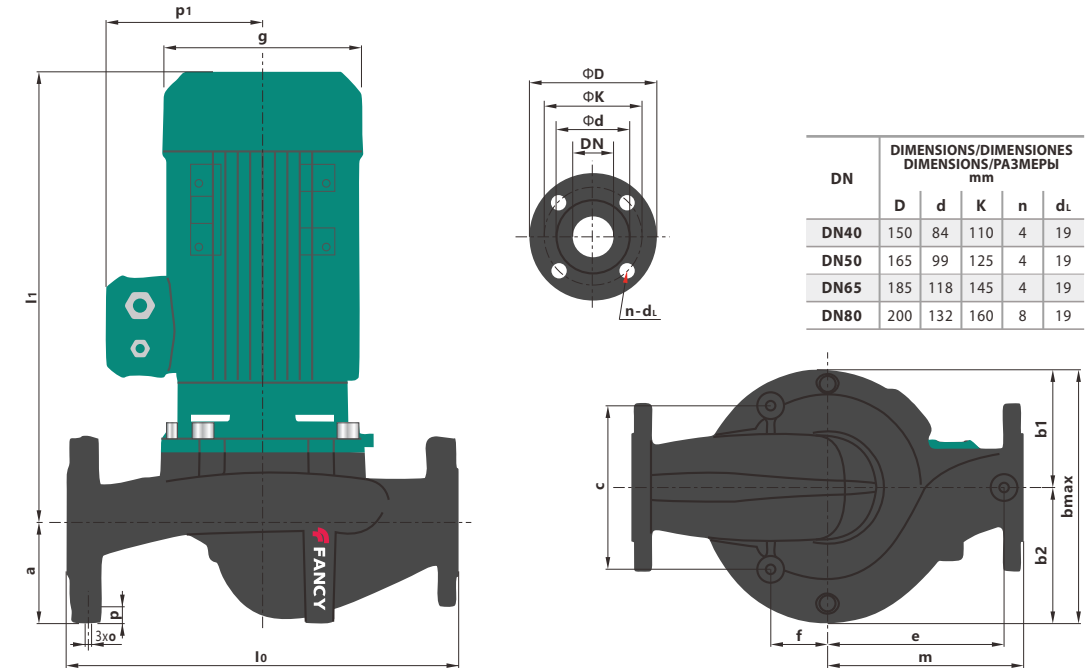

MODEL MODELO MODÈLE МОДЕЛЬ	DIMENSIONS/DIMENSIONES/DIMENSIONS/РАЗМЕРЫ mm															NW Kg
	DN	lo	a	b1	b2	bmax	c	e	f	g	l1	m	o	p	p1	
40/120-1.5/2	40	320	75	113	121	234	90	40	50	193	374	160	M10	20	151	30
40/130-2.2/2	40	320	75	113	121	234	90	40	50	193	374	160	M10	20	151	32
40/150-3/2	40	320	75	113	121	234	90	40	50	217	386	160	M10	20	160	38
40/160-4/2	40	320	75	113	121	234	90	40	50	232	420	160	M10	20	169	44
40/175-5.5/2	40	340	82	113	129	279	130	149	58	279	511	170	M10	20	182	69
40/195-7.5/2	40	440	110	145	149	294	180	172	78	279	520	190	M10	20	188	81
50/120-1.5/2	50	340	86	116	131	247	104	40	50	193	376	170	M10	20	151	33
50/130-2.2/2	50	340	86	116	131	247	104	40	50	193	376	170	M10	20	151	35
50/140-3/2	50	340	86	116	131	247	104	40	50	217	388	170	M10	20	160	41
50/150-4/2	50	340	86	116	131	247	104	40	50	232	422	170	M10	20	169	47
50/165-5.5/2	50	340	103	120	138	279	164	143	48	279	526	170	M10	20	188	74
50/175-5.5/2	50	340	103	120	138	279	164	143	48	279	526	170	M10	20	188	74
50/175-7.5/2	50	340	103	120	138	279	164	143	48	279	526	170	M10	20	188	76
50/185-7.5/2	50	440	120	145	150	295	160	170	70	279	521	190	M10	20	188	83
65/115-1.5/2	65	340	80	100	118	218	-	155	155	193	387	170	M10	20	151	35
65/110-2.2/2	65	340	93	111	132	243	135	32	63	193	379.5	162	M10	20	149.5	37
65/120-3/2	65	340	93	111	132	243	135	32	63	217	414	162	M10	20	169.5	43
65/130-4/2	65	340	93	111	132	243	135	32	63	232	445.5	162	M10	20	174.5	51
65/145-5.5/2	65	340	120	112	134	279	140	140	60	279	531	160	M12	20	188	74
65/155-5.5/2	65	340	120	112	134	279	140	140	60	279	531	160	M12	20	188	74
65/155-7.5/2	65	340	120	112	134	279	140	140	60	279	531	160	M12	20	188	82
65/165-5.5/2	65	430	110	126	146	279	180	195	60	279	531	215	M12	20	188	78
65/175-5.5/2	65	430	110	126	146	279	180	195	60	279	531	215	M12	20	188	79
65/175-7.5/2	65	430	110	126	146	279	180	195	60	279	531	215	M12	20	188	85
80/105-3/2	80	360	105	125	157	282	135	40	55	217	421.5	180	M10	20	169.5	48
80/110-4/2	80	360	105	125	157	282	135	40	55	232	453	180	M10	20	174.5	56
80/120-4/2	80	360	105	125	157	282	135	40	55	232	453	180	M10	20	174.5	56
80/145-5.5/2	80	400	105	123	151	279	180	173	57	279	548	200	M12	20	188	81
80/155-7.5/2	80	400	105	123	151	279	180	173	57	279	548	200	M12	20	188	89