

TECHNICAL DATA/DATOS TÉCNICOS/DONNÉES TECHNIQUES/ТЕХНИЧЕСКИЕ ДАННЫЕ

60Hz n≈1750l/min

| MODEL MODELO MODÈLE МОДЕЛЬ | DN mm | Power Potencia Puissance Мощность | | Volt. V | Amp. | mm | Q m³/h | H m | Qm m³/h | Hm m | n rpm | DIMENSIONS/DIMENSIONES DIMENSIONS/РАЗМЕРЫ mm | | | | | | | | | | NW. kgs |
|-------------------------------------|----------|--|----|------------|------|-----|-----------|--------|------------|---------|----------|--|-----|-----|------|-----|-----|--------|-----|-----|--|------------|
| | | kw | hp | | | | | | | | | L | L1 | B | H | H1 | D0 | n-d0 | D1 | | | |
| 100WQ100-20-11S4 | 100 | 11 | 15 | 380 | 21.8 | ø35 | 100 | 20 | 170 | 25.5 | 1750 | 620 | 359 | 521 | 1008 | 208 | 170 | 4-17.5 | 210 | 200 | | |
| 150WQ180-11-11S4 | 150 | 11 | 15 | 380 | 21.8 | ø45 | 180 | 11 | 320 | 20 | 1750 | 566 | 325 | 485 | 1017 | 212 | 225 | 8-17.5 | 265 | 205 | | |
| 200WQ300-7-11S4 | 200 | 11 | 15 | 380 | 21.8 | ø50 | 300 | 7 | 350 | 21 | 1750 | 558 | 323 | 470 | 1037 | 222 | 280 | 8-18.5 | 320 | 210 | | |
| 100WQ100-25-15S4 | 100 | 15 | 20 | 380 | 29.4 | ø35 | 100 | 25 | 165 | 36 | 1750 | 620 | 359 | 521 | 1008 | 208 | 170 | 4-17.5 | 210 | 220 | | |
| 150WQ180-15-15S4 | 150 | 15 | 20 | 380 | 29.4 | ø45 | 180 | 15 | 365 | 24 | 1750 | 566 | 325 | 485 | 1017 | 212 | 225 | 8-17.5 | 265 | 225 | | |
| 200WQ250-11-15S4 | 200 | 15 | 20 | 380 | 29.4 | ø50 | 250 | 11 | 365 | 23.5 | 1750 | 558 | 323 | 470 | 1037 | 222 | 280 | 8-18.5 | 320 | 230 | | |
| 100WQ100-30-18.5S4 | 100 | 18.5 | 25 | 380 | 35.5 | ø35 | 100 | 30 | 165 | 43 | 1750 | 620 | 359 | 521 | 1047 | 222 | 170 | 4-17.5 | 210 | 250 | | |
| 150WQ180-20-18.5S4 | 150 | 18.5 | 25 | 380 | 35.5 | ø45 | 180 | 20 | 410 | 27.5 | 1750 | 627 | 372 | 550 | 1030 | 208 | 225 | 8-17.5 | 265 | 260 | | |
| 200WQ250-15-18.5S4 | 200 | 18.5 | 25 | 380 | 35.5 | ø50 | 250 | 15 | 520 | 19.5 | 1750 | 670 | 395 | 521 | 1045 | 271 | 280 | 8-18.5 | 320 | 270 | | |
| 100WQ100-35-22S4 | 100 | 22 | 30 | 380 | 42.2 | ø35 | 100 | 35 | 165 | 46 | 1750 | 620 | 359 | 521 | 1047 | 222 | 170 | 4-17.5 | 210 | 330 | | |
| 150WQ180-25-22S4 | 150 | 22 | 30 | 380 | 42.2 | ø45 | 180 | 25 | 425 | 29 | 1750 | 627 | 372 | 550 | 1030 | 208 | 225 | 8-17.5 | 265 | 340 | | |
| 200WQ250-20-22S4 | 200 | 22 | 30 | 380 | 42.2 | ø50 | 250 | 20 | 540 | 25 | 1750 | 670 | 395 | 521 | 1045 | 225 | 280 | 8-18.5 | 320 | 350 | | |
| 100WQ100-45-30S4 | 100 | 30 | 40 | 380 | 56.9 | ø35 | 100 | 45 | 190 | 53 | 1750 | / | / | / | / | / | 170 | 4-17.5 | 210 | 445 | | |
| 150WQ180-30-30S4 | 150 | 30 | 40 | 380 | 56.9 | ø45 | 180 | 30 | 410 | 37 | 1750 | / | / | / | / | / | 225 | 8-17.5 | 265 | 450 | | |
| 200WQ250-22-30S4 | 200 | 30 | 40 | 380 | 56.9 | ø50 | 250 | 22 | 470 | 30.5 | 1750 | / | / | / | / | / | 280 | 8-18.5 | 320 | 460 | | |
| 250WQ600-9-30S4 | 250 | 30 | 40 | 380 | 56.9 | ø55 | 600 | 9 | 710 | 25 | 1750 | / | / | / | / | / | 335 | 12-16 | 375 | 485 | | |
| 150WQ180-37-37S4 | 150 | 37 | 50 | 380 | 69.8 | ø45 | 180 | 37 | 340 | 41 | 1750 | 630 | 372 | 550 | 1290 | 175 | 225 | 8-17.5 | 265 | 510 | | |
| 200WQ350-25-37S4 | 200 | 37 | 50 | 380 | 69.8 | ø50 | 350 | 25 | 510 | 37 | 1750 | 630 | 395 | 525 | 1310 | 185 | 280 | 8-18.5 | 320 | 520 | | |
| 250WQ600-12-37S4 | 250 | 37 | 50 | 380 | 69.8 | ø55 | 600 | 12 | 880 | 22.5 | 1750 | 710 | 410 | 600 | 1345 | 200 | 335 | 12-16 | 375 | 550 | | |
| 300WQ800-9-37S4 | 300 | 37 | 50 | 380 | 69.8 | ø60 | 800 | 9 | 920 | 21.5 | 1750 | 789 | 460 | 670 | 1376 | 313 | 395 | 12-20 | 440 | 560 | | |
| 150WQ200-40-45S4 | 150 | 45 | 60 | 380 | 83.9 | ø45 | 200 | 40 | 350 | 46 | 1750 | 630 | 372 | 550 | 1290 | 175 | 225 | 8-17.5 | 265 | 640 | | |
| 200WQ400-25-45S4 | 200 | 45 | 60 | 380 | 83.9 | ø50 | 400 | 25 | 600 | 38.5 | 1750 | 670 | 395 | 525 | 1310 | 185 | 280 | 8-18.5 | 320 | 650 | | |
| 250WQ600-15-45S4 | 250 | 45 | 60 | 380 | 83.9 | ø55 | 600 | 15 | 720 | 28 | 1750 | 710 | 410 | 600 | 1345 | 200 | 335 | 12-16 | 375 | 680 | | |
| 300WQ800-12-45S4 | 300 | 45 | 60 | 380 | 83.9 | ø60 | 800 | 12 | 1050 | 30 | 1750 | 789 | 460 | 670 | 1379 | 313 | 375 | 12-20 | 440 | 690 | | |

MATERIAL/MATERIAL/MATÉRIEL/МАТЕРИАЛ

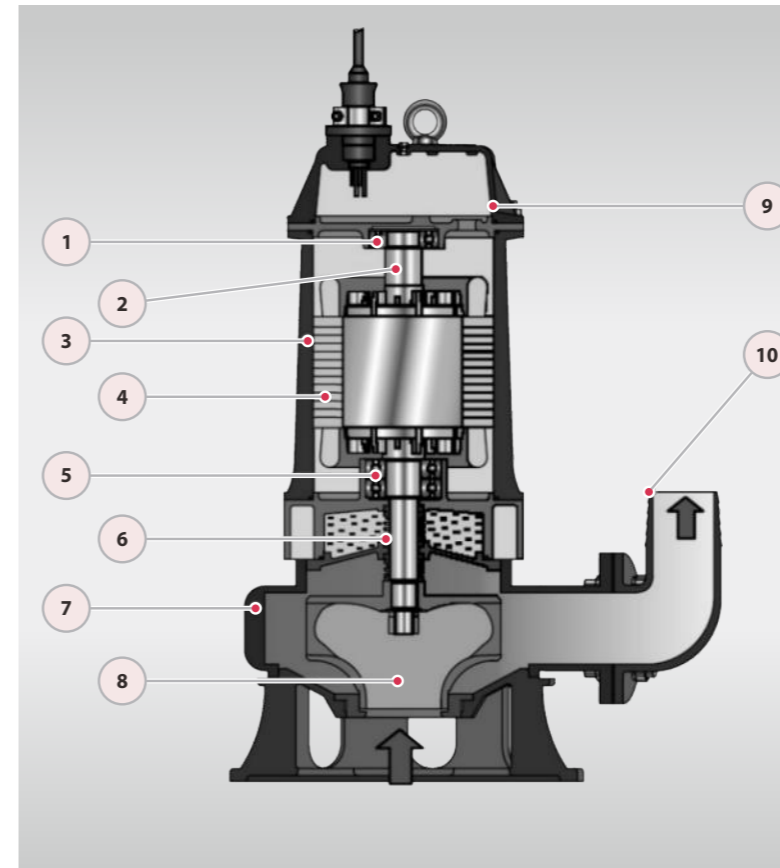

| No. | Description/Descripción Description/Описание | Material/Material Matériel/Материал |
|-----|--|---|
| 1 | Bearing Cojinete Palier Подшипник | Ball Bearing Bola Rodamiento Palier Balle шарикоподшипник |
| 2 | Shaft Eje Arbre Вал | SUS304/316 Inox304/316 Inox304/316 СУС304/316 |
| 3 | Motor Case Cuerpo de Motor Boitier du moteur Мотор Корпус | SUS304/316 Inox304/316 Inox304/316 СУС304/316 |
| 4 | Stator/Rotor Estator/Rotor Stator/Rotor Статор/ротор | Silicon Steel/Copper Silicio/Cobre Silicium/Cuivre Кремниевая сталь/медь |
| 5 | Bearing Cojinete Palier Подшипник | Ball Bearing Bola Rodamiento Palier Balle шарикоподшипник |
| 6 | Mechanical Seal Cierre Mecánico Garniture Механическая печать | SiC&SiC SiC&SiC SiC&SiC SiC&SiC |
| 7 | Pump Case Cuerpo de Bomba Boitier pompe Корпус насоса | SUS304/316 Inox304/316 Inox304/316 СУС304/316 |
| 8 | Impeller Impulsor Roue Импульсор | SUS304/316 Inox304/316 Inox304/316 СУС304/316 |
| 9 | Motor cover Tapa de motor Capot moteur Крышка мотора | SUS304/316 Inox304/316 Inox304/316 СУС304/316 |
| 10 | Output flange Brida de salida Bride de sortie Выходной фланец | SUS304/316 Inox304/316 Inox304/316 СУС304/316 |

DIMENSIONS AND N.W./DIMENSIONES Y PESOS/DIMENSIONS ET POIDS/РАЗМЕРЫ И ВЕС

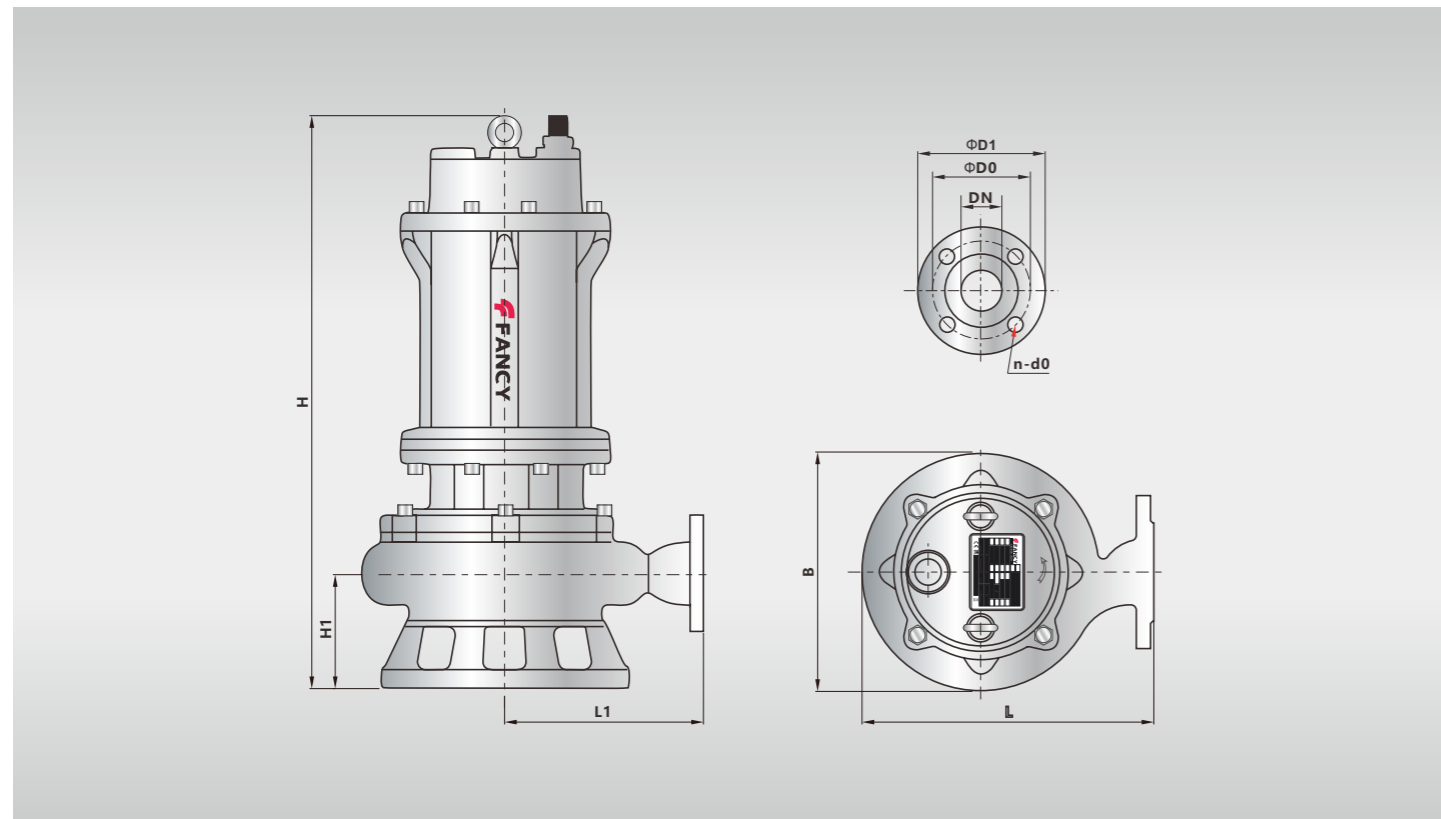

PERFORMANCE CURVE/CURVA DE RENDIMENTO/СОРБЕ/КРИВАЯ ПРОИЗВОДИТЕЛЬНОСТИ

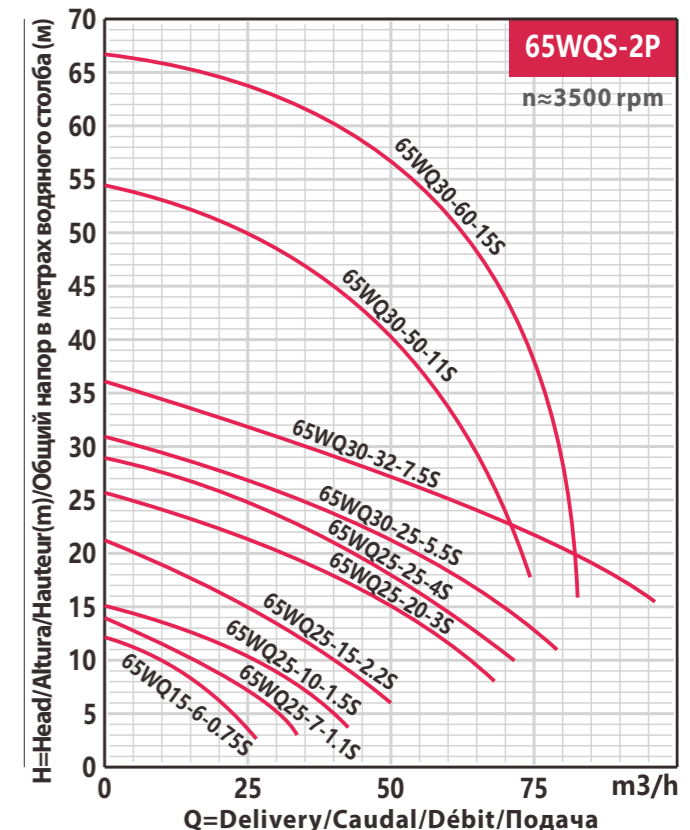
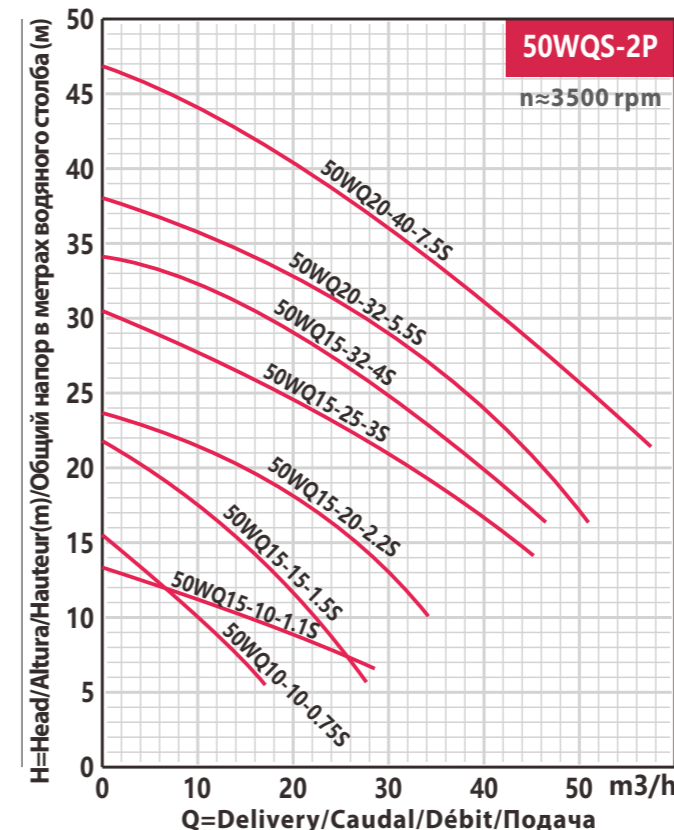

PERFORMANCE CURVE/CURVA DE RENDIMENTO/COURBE DE PERFORMANCE/КРИВАЯ ПРОИЗВОДИТЕЛЬНОСТИ

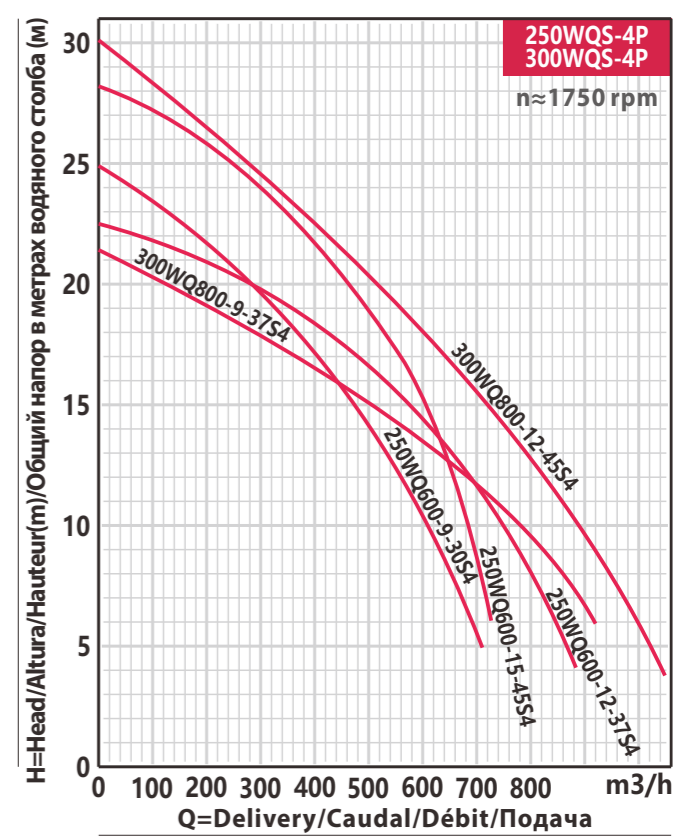
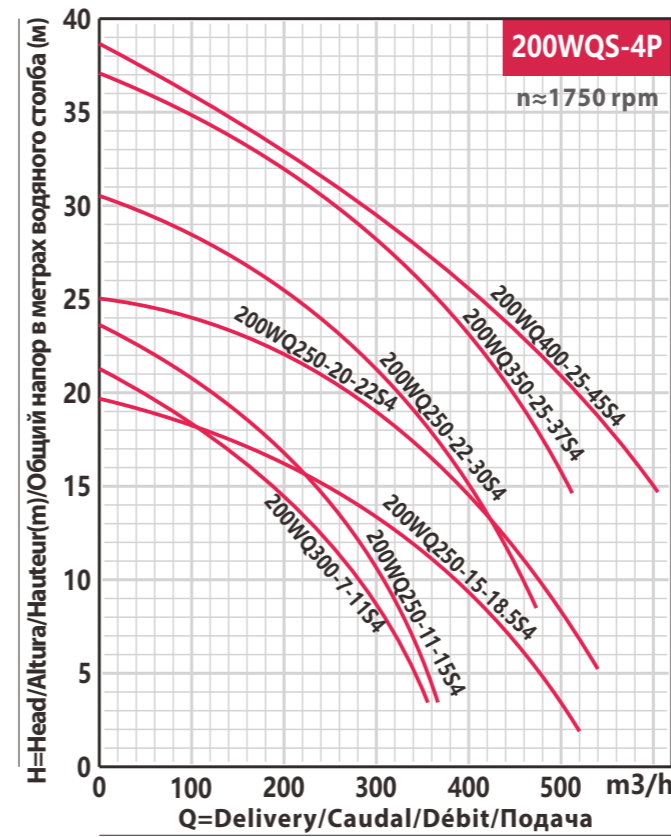
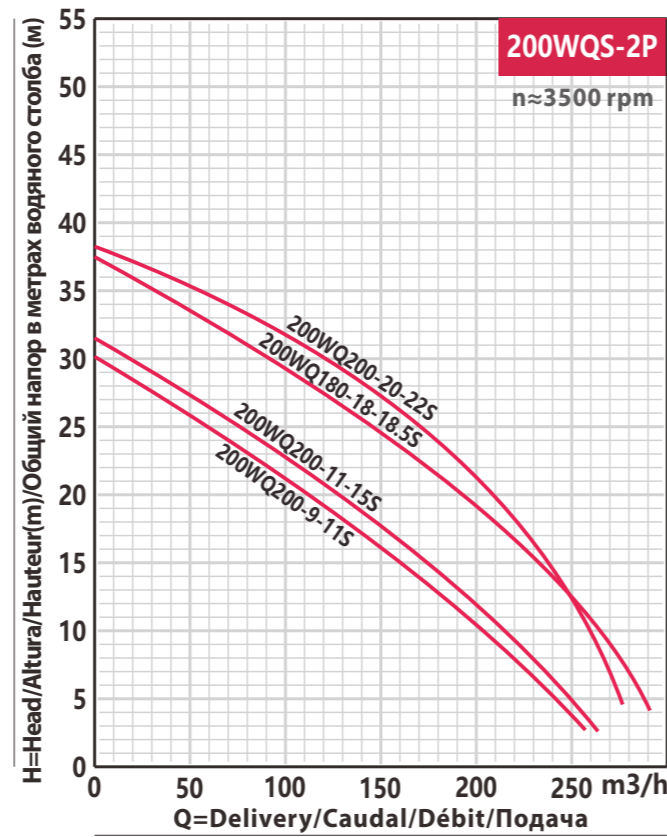
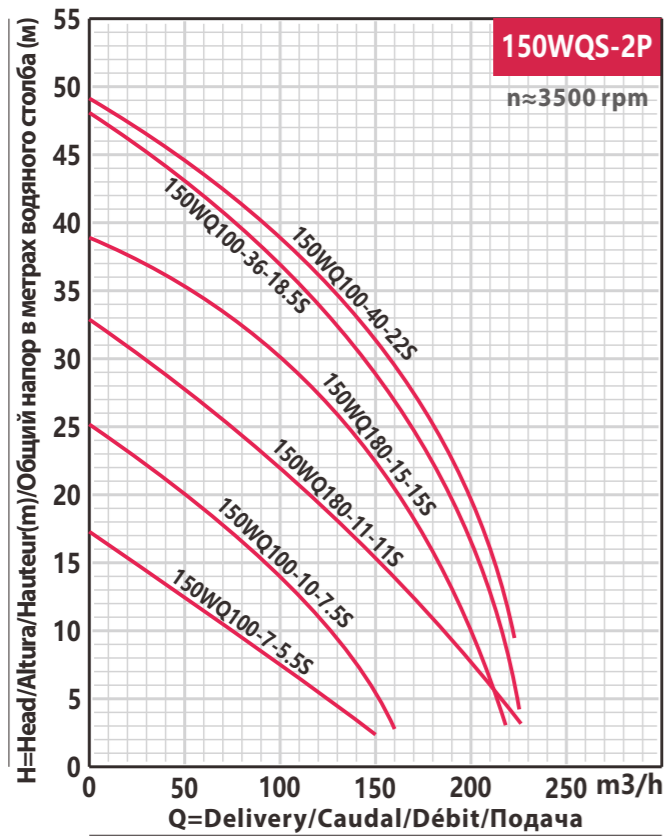
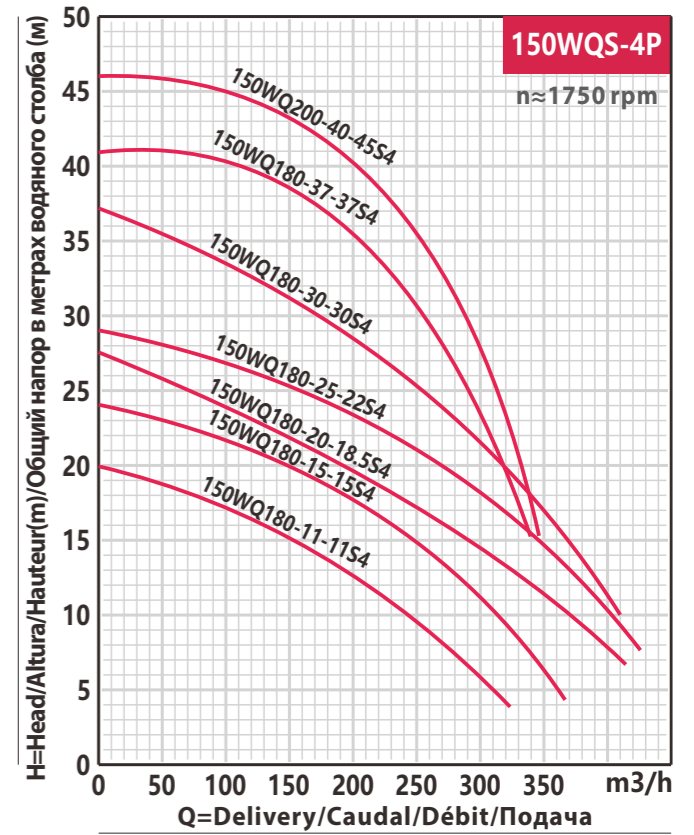
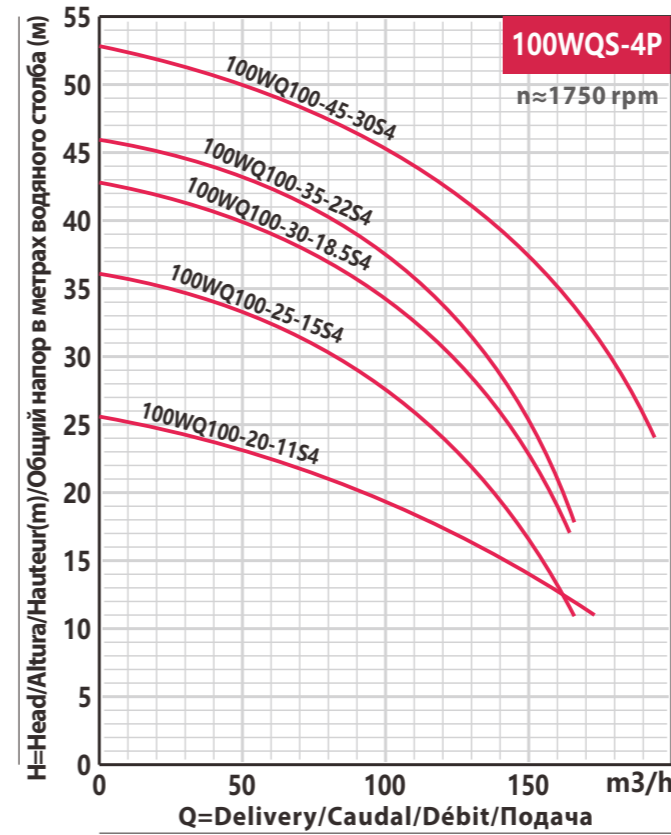
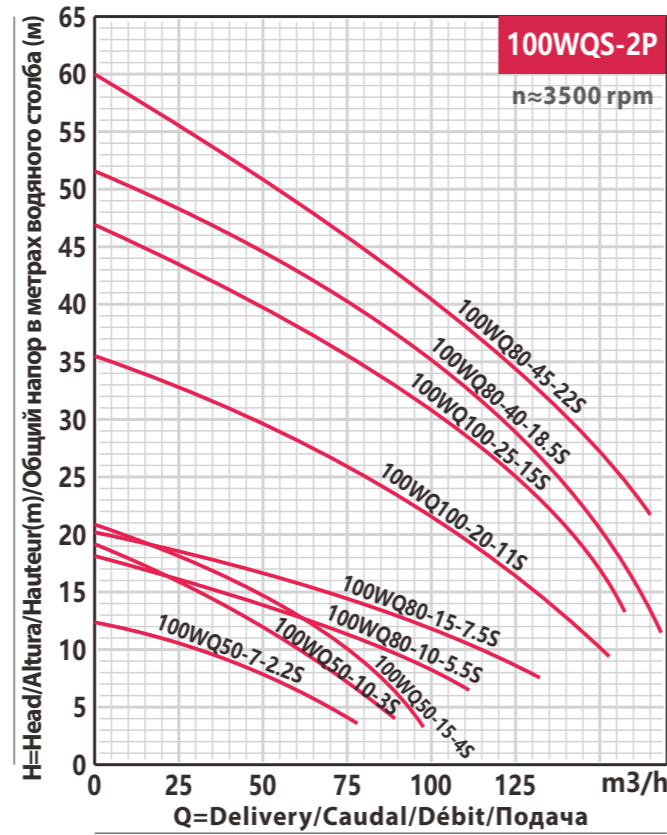
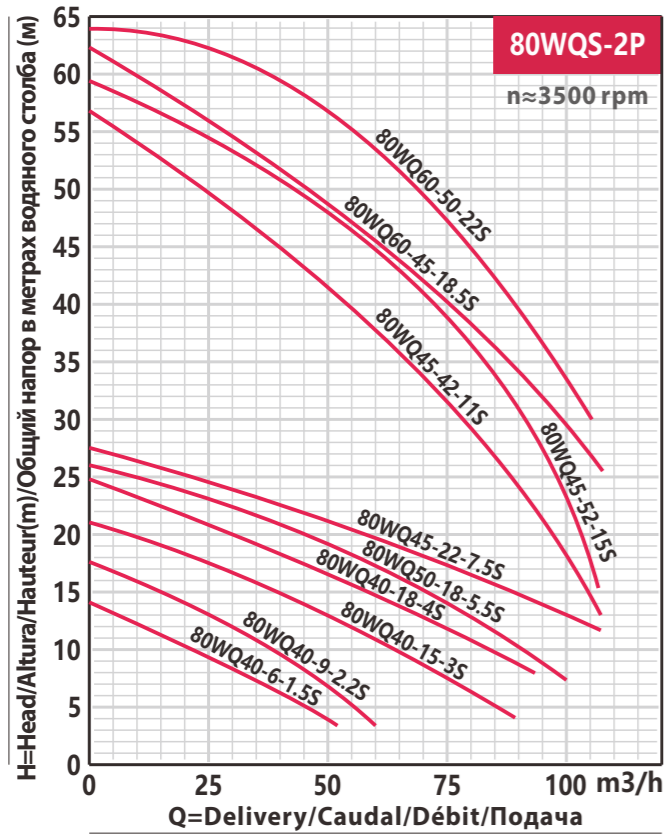

PERFORMANCE CURVE/CURVA DE RENDIMENTO/COURBE DE PERFORMANCE/КРИВАЯ ПРОИЗВОДИТЕЛЬНОСТИ