

KBZ

n≈3500/1750rpm



Submersible slurry pump
Bomba de lodo sumergible
Pompe à lisier submersible
Погружной шламовый насос

FANCY

TECHNICAL DATA/DATOS TÉCNICOS/DONNÉES TECHNIQUES/ТЕХНИЧЕСКИЕ ДАННЫЕ

60Hz n≈3500l/min

MODEL MODELO MODÈLE МОДЕЛЬ	DN	Power Potencia Puissance Мощность	380V	Q=Delivery/Caudal/Débit/Подача																	DIMENSIONS DIMENSIONES DIMENSIONS РАЗМЕРЫ					NW.							
				mm	kw	hp	Amp.	mm	GPM 0 53 66 79 115 132 159 176 211 242 264 330 396 449 551 652 687																A		A1	B	D	H	W1	kgs	
									l/min 0 200 250 300 433 500 600 667 800 917 1000 1250 1500 1700 2083 2467 2600																								
1-ph	3-ph						m³/h 0 12 15 18 26 30 36 40 48 55 60 75 90 102 125 148 156																										
							H=Head(m)/Altura(m)/Hauteur(m)/Общий напор в метрах водяного столба (м)																										
KBZm21.5	KBZ21.5	50	1.5	2	3.7	ø8.5	22	16.5	15	13	7.5	-	-	-	-	-	-	-	-	-	-	-	-	-	-	-	235	173	535	216	505	120	36
-	KBZ22.2	50	2.2	3	5.3	ø8.5	26	23	21.5	20	14.6	11	5	-	-	-	-	-	-	-	-	-	-	-	-	-	235	173	535	216	505	120	39
-	KBZ23.7	50	3.7	5	8.1	ø8.5	34.2	30	28.5	27	21	15.5	7	-	-	-	-	-	-	-	-	-	-	-	-	-	283	208	628	252	629	150	63
KBZm31.5	KBZ31.5	80	1.5	2	3.7	ø8.5	14.5	13	12.5	11.8	9	8	4.6	2	-	-	-	-	-	-	-	-	-	-	-	-	235	173	535	216	505	120	36
-	KBZ32.2	80	2.2	3	5.3	ø8.5	19	18	17.5	17	15	14	12	10.7	7.2	4	-	-	-	-	-	-	-	-	-	-	235	173	535	216	505	120	39
-	KBZ33.7	80	3.7	5	8.1	ø8.5	29	26	25	24	21.5	20	17	15	11	7	-	-	-	-	-	-	-	-	-	-	283	208	628	252	629	150	63
-	KBZ35.5	80	5.5	7.5	12	ø8.5	34.5	32	31.5	31	29	27.5	26	24.5	21.7	18.5	16	5	-	-	-	-	-	-	-	-	283	208	671	252	590	150	77
-	KBZ43.7	100	3.7	5	8.1	ø8.5	18.5	-	-	-	17	16.5	16	15	14	12.5	11.5	8.2	4	-	-	-	-	-	-	-	283	208	642	252	629	150	63
-	KBZ45.5	100	5.5	7.5	12	ø8.5	23	-	-	-	21	20.5	20	19	18	16.5	16	12.3	8	4	-	-	-	-	-	-	283	208	686	252	590	150	77
-	KBZ47.5	100	7.5	10	15.8	ø11.5	39.8	-	-	-	36.5	36	35	33.5	31	28.5	26	17	3	-	-	-	-	-	-	-	330	240	764	314	676	190	106
-	KBZ411	100	11	15	23.2	ø11.5	48	-	-	-	45	44	43.5	42	40	37	35	21	4	-	-	-	-	-	-	-	373	255	807	350	695	190	136
-	KBZ415	100	15	20	31.1	ø11.5	56	-	-	-	53.5	53	52	50.2	48	44.5	42	28	5	-	-	-	-	-	-	-	373	255	842	350	755	190	144
-	KBZ67.5	150	7.5	10	15.8	ø19.5	31	-	-	-	-	-	-	25.8	24	23	22	19	15.3	11	3	-	-	-	-	-	330	240	790	314	676	190	108
-	KBZ611	150	11	15	23.2	ø19.5	32	-	-	-	-	-	-	30	29.7	29	28	26.2	24	22	16	6	-	-	-	-	373	255	807	350	695	190	139
-	KBZ615	150	15	20	31.1	ø19.5	40.1	-	-	-	-	-	-	36.5	36	35.5	35	33.3	31.7	30	23	10	3	-	-	-	373	255	842	350	755	190	146

60Hz KBD n≈3500l/min KBS n≈1750l/min

MODEL MODELO MODÈLE МОДЕЛЬ	DN	Power Potencia Puissance Мощность	380V	Q=Delivery/Caudal/Débit/Подача																	DIMENSIONS DIMENSIONES DIMENSIONS РАЗМЕРЫ					NW.						
				mm	kw	hp	Amp.	mm	GPM 0 66 79 132 198 264 396 441 639 881 1101 1322 1630																A		A1	B	D	H	W1	kgs
									l/min 0 250 300 500 750 1000 1500 1667 2417 3333 4167 5000 6167																							
1-ph	3-ph						m³/h 0 15 18 30 45 60 90 100 145 200 250 300 370																									
							H=Head(m)/Altura(m)/Hauteur(m)/Общий напор в метрах водяного столба (м)																									
KBDm21.5	KBD21.5	50	1.5	2	3.7	ø10	20	14.5	13	4.5	-	-	-	-	-	-	-	-	-	-	-	-	-	-	-	235	173	557	216	522	135	37
-	KBD22.2	50	2.2	3	5.3	ø10	25	21	19.5	10	-	-	-	-	-	-	-	-	-	-	-	-	-	-	-	235	173	557	216	522	135	40
-	KBD33.7	80	3.7	5	8.1	ø10	30	26	25	20.5	13.5	4	-	-	-	-	-	-	-	-	-	-	-	-	-	283	208	636	252	642	165	64
-	KBD43.7	100	3.7	5	8.1	ø10	18	17.5	17	16	14	11	2	-	-	-	-	-	-	-	-	-	-	-	-	283	208	661	252	642	165	65
-	80KBS44	80	4	5.5	10.2	ø30	15	-	-	13	11.6	10	5	2.5	-	-	-	-	-	-	-	-	-	-	-	350	260	816	326	730	250	108.5
-	100KBS46	100	6	8	13.8	ø30	17	-	-	-	14.5	13.3	10	9	3	-	-	-	-	-	-	-	-	-	-	415	305	844	373	730	250	141
-	150KBS49	150	9	12	19.5	ø30	21.5	-	-	-	19.3	18.3	16	15	10	2.5	-	-	-	-	-	-	-	-	-	434	324	889	407	776	250	171
-	200KBS415	200	15	20	30.1	ø30	22	-	-	-	-	-	-	-	18.5	16.2	13.5	10	2	-	-	-	-	-	-	484	352	1121	457	980	295	260
-	200KBS422	200	22	30	42.1	ø30	32	-	-	-	-	-	-	-	27	24	20	14	1.5	-	-	-	-	-	-	578	442	1245	528	1200	330	408

DESCRIPTION/DESCRIPCIONES/DESCRIPTION/ОПИСАНИЕ

- ◆ Submersible mud pump with upper water outlet design.
 - ◆ Integral casting water outlet channel on the side of motor.
 - ◆ Good cooling effect, can run above the water surface.
 - ◆ Special mechanical seal structure ensures harsh working.
 - ◆ Semi-open impeller casted with wear-resistant alloy.
 - ◆ KBD/KBS heavy-duty slurry pump with agitator.
 - ◆ KBS Submersible slurry pump with a 4-pole motor.
 - ◆ Power≤11kW is equipped with built-in thermal protector.
- ◆ Bomba de lodo sumergible con diseño de salida de agua superior.
 - ◆ Canal de salida de agua de fundición integral en el costado del motor.
 - ◆ Buen efecto de enfriamiento, puede correr por encima superficie agua.
 - ◆ La estructura especial del sello mecánico garantiza un trabajo duro.
 - ◆ Impulsor semiabierto fundido con aleación resistente al desgaste.
 - ◆ Bomba de lodo de alta resistencia KBD/KBS con agitador.
 - ◆ KBS Bomba sumergible para lodos con motor de 4 polos.
 - ◆ Power≤11kW está equipado con protector térmico incorporado.
- ◆ Pompe à boue submersible avec conception de sortie d'eau supérieure.
 - ◆ Canal de sortie d'eau de coulée intégré sur le côté du moteur.
 - ◆ Bon effet de refroidissement, peut fonctionner au-dessus surface l'eau.
 - ◆ La structure spéciale de la garniture mécanique garantit un travail difficile.
 - ◆ Roue semi-ouverte moulée en alliage résistant à l'usure.
 - ◆ Pompe à lisier robuste KBD/KBS avec agitateur.
 - ◆ Pompe à lisier submersible KBS avec moteur 4 pôles.
 - ◆ La puissance≤11kW est équipée d'un protecteur thermique intégré.
- ◆ Погружной буровой насос с верхним выпуском воды.
 - ◆ Встроенный канал для выпуска литейной воды сбоку от двигателя.
 - ◆ Хороший охлаждающий эффект, может работать над поверхностью воды.
 - ◆ Специальная структура уплотнения обеспечивает суровую работу.
 - ◆ Полуоткрытое рабочее колесо, отлитое из износостойкого сплава.
 - ◆ Шламовый насос для тяжелых условий эксплуатации KBD/KBS с мешалкой.
 - ◆ KBS Погружной шламовый насос с 4-полюсным двигателем.
 - ◆ Мощность≤11кВт оснащен встроенной термозащитой.

USING/UTILIZACIÓN/UTILISATION/ИСПОЛЬЗОВАНИЕ

- ◆ Water temperature: up to 40°C
 - ◆ Maximum immersion depth: 25m(KBZ&KBD), 15m(KBS)
 - ◆ Solid passage ∅ : 8.5-30mm, Cable length: 8m
- ◆ Temperatura del agua: hasta 40°C
 - ◆ Profundidad máxima de inmersión: 25m(KBZ&KBD), 15m(KBS)
 - ◆ Paso sólido ∅ : 8.5-30mm, Longitud cable: 8m
- ◆ Température de l'eau : jusqu'à 40°C
 - ◆ Profondeur d'immersion maximale : 25m(KBZ&KBD), 15m(KBS)
 - ◆ Passage solide ∅ : 8.5-30mm, Longueur câble : 8m
- ◆ Температура воды: до 40°C
 - ◆ Максимальная глубина погружения: 25м(KBZ&KBD), 15м(KBS)
 - ◆ Сплошной проход ∅ : 8.5-30мм, Длина кабеля: 8м

MODEL CODE/CÓDIGO MODELO/COE MODÈLE/КОД МОДЕЛИ

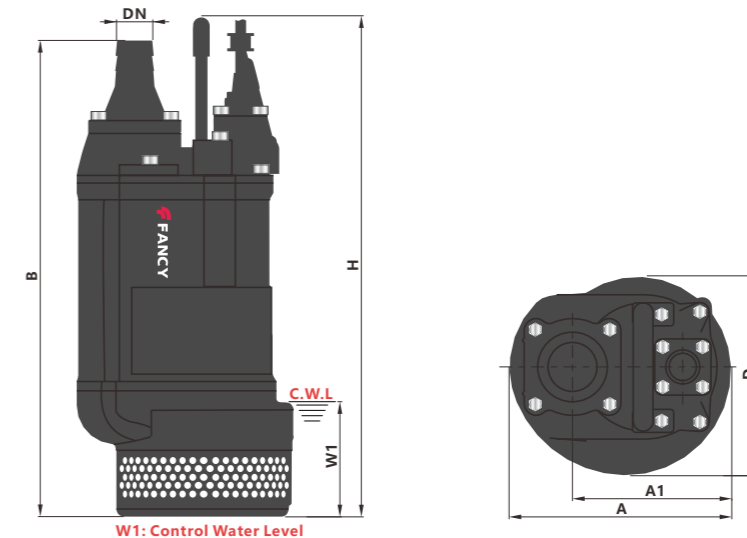
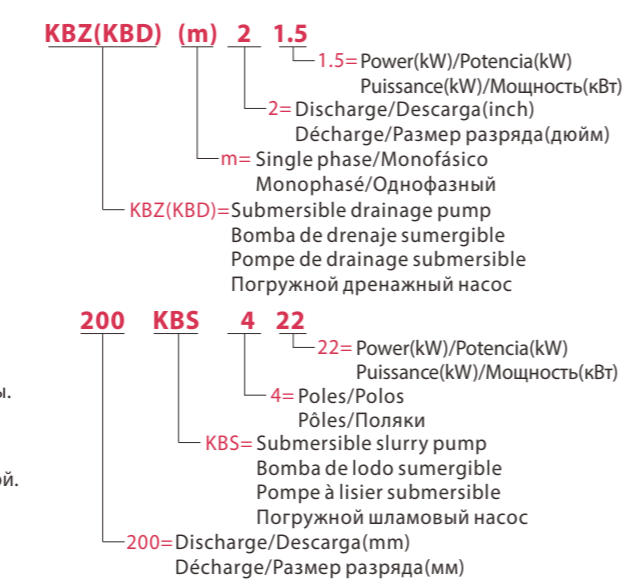

MATERIAL/MATERIAL/MATÉRIEL/МАТЕРИАЛ

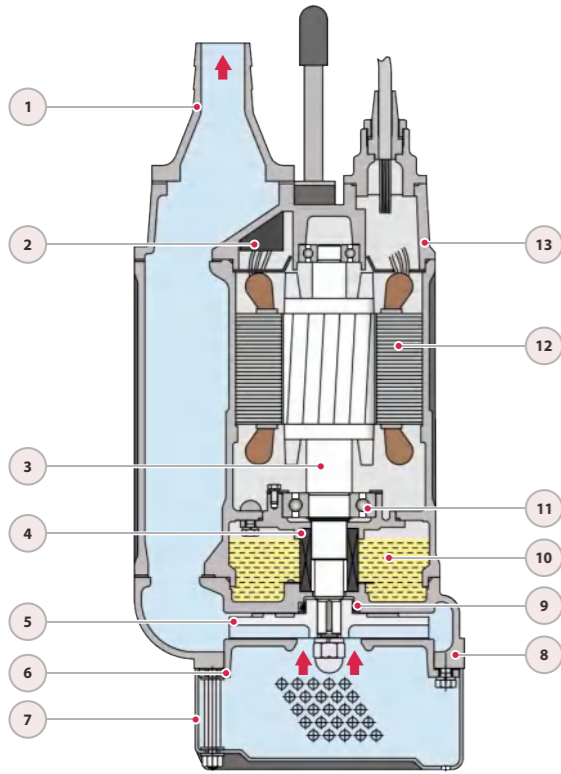

No.	Description/Descripción Description/Описание	Material/Material Matériel/Mатериал
1	Output/salida Sortie/Выходной	Cast iron/Fundición Fonte/Чугун
2	Thermal protector/Protector térmico Protecteur thermique/Термальный протектор	Assembly/Asamblea Assemblée/Ассамблея
3	Shaft/Eje Arbre/Вал	SUS420/Inox420 Inox420/СУС420
4	Mechanical Seal/Cierre Mecánico Garniture/Механическая печать	SiC-SiC/SiC-SiC SiC-SiC/SiC-SiC
5	Impeller/Impulsor Roue/Импульсор	Chromium alloy/Aleación cromo Alliage chrome/Хромовый сплав
6	Base/Base Base/База	Chromium alloy/Aleación cromo Alliage chrome/Хромовый сплав
7	Strainer/Colador Passoire/Ситечко	Steel/Acero Acier/Сталь
8	Pump Case/Cuerpo de Bomba Boitier pompe/Корпус насоса	Cast iron/Fundición Fonte/Чугун
9	Reinforce seal/Reforzar sello Renforcer joint/Усилить уплотнение	Rubber/Goma Caoutchouc/Резина
10	Chamber/Sala Chambre/Камера	Cast iron/Fundición Fonte/Чугун
11	Bearing/Cojinete Palier/Подшипник	Ball Bearing/Bola Rodamiento Palier Balle/шарикоподшипник
12	Stator/Estator Stator/Статор	Silicon/Copper/Silicio/Cobre Silicium/Cuivre/Кремниевая/медь
13	Motor cover/Tapa de motor Capot moteur/Крышка мотора	Cast iron/Fundición Fonte/Чугун

PERFORMANCE/RENDIMENTO/ПРОИЗВОДИТЕЛЬНОСТИ

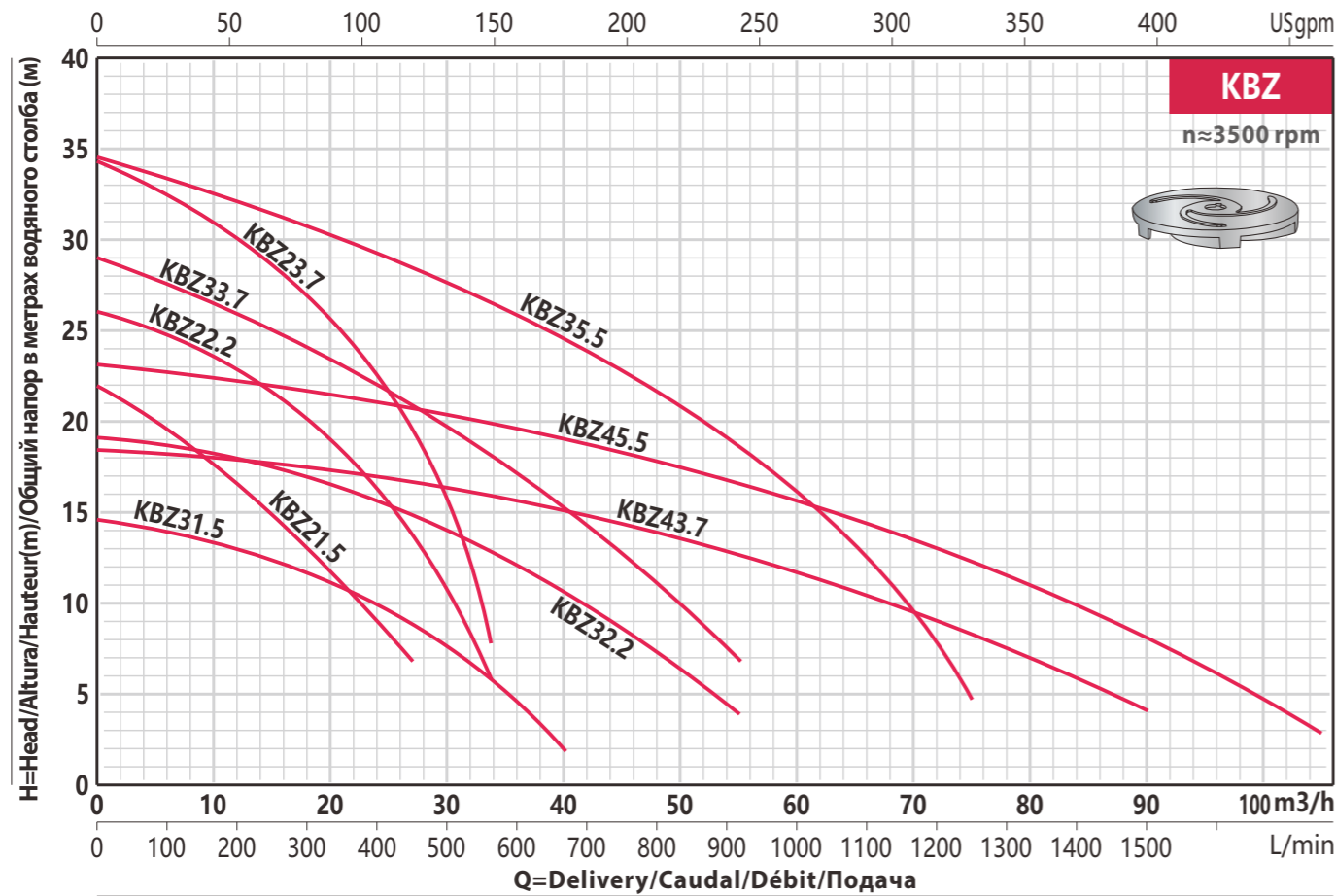

PERFORMANCE CURVE/CURVA DE RENDIMENTO/СОРБЕ DE PERFORMANCE/КРИВАЯ ПРОИЗВОДИТЕЛЬНОСТИ

