

QDX

n≈3500rpm

Submersible water pump
Bomba de agua sumergible
Pompe à eau submersible
Погружной водяной насос



QDX

QDXB

DESCRIPTION/DESCRIPCIONES/DESCRIPTION/ОПИСАНИЕ

- ◆ Aluminum and SS304 submersible water pump.
- ◆ Different casing design for aluminum submersible pump.
- ◆ Compact and proportional design.
- ◆ Ensuring durability and easy in operation.
- ◆ Impeller in aluminum or plastic.
- ◆ High efficient motor, with protection IP68 class F.
- ◆ Quality bearing, wear resistance mechanical seal.
- ◆ Better hydraulic characteristics.

- ◆ Bomba de agua sumergible de aluminio y SS304.
- ◆ Diseño de carcasa diferente para bomba sumergible.
- ◆ Diseño compacto y proporcional.
- ◆ Garantizar la durabilidad y fácil en la operación.
- ◆ Impulsor en aluminio o plástico.
- ◆ Motor de alta eficiencia, con protección IP68 clase F.
- ◆ Cojinete de calidad, sello mecánico resistente al desgaste.
- ◆ Mejores características hidráulicas.

- ◆ Pompe à eau submersible en aluminium et SS304.
- ◆ Conception de boîtier différente pour pompe submersible.
- ◆ Conception compacte et proportionnelle.
- ◆ Assurer la durabilité et la facilité d'utilisation.
- ◆ Turbine en aluminium ou en plastique.
- ◆ Moteur à haut rendement, avec protection IP68 classe F.
- ◆ Roulement de qualité, joint mécanique résistant à l'usure.
- ◆ Meilleures caractéristiques hydrauliques.

- ◆ Погружной водяной насос из алюминия и нержавеющей стали SS304.
- ◆ Различная конструкция корпуса алюминиевого погружного насоса.
- ◆ Компактный и пропорциональный дизайн.
- ◆ Обеспечение долговечности и простоты в эксплуатации.
- ◆ Рабочее колесо из алюминия или пластика.
- ◆ Высокоэффективный двигатель с классом защиты IP68 F.
- ◆ Качественный подшипник, износостойкое механическое уплотнение.
- ◆ Улучшенные гидравлические характеристики.

USING/UTILIZACIÓN/UTILISATION/ИСПОЛЬЗОВАНИЕ

- ◆ Water temperature: up to 40°C
- ◆ Maximum immersion depth: 5m
- ◆ Solid passage $\leq 0.2\text{mm}$, Cable length: 8m

- ◆ Temperatura del agua: hasta 40°C
- ◆ Profundidad máxima de inmersión: 5m
- ◆ Paso sólido $\leq 0.2\text{mm}$, Longitud cable: 8m

- ◆ Température de l'eau : jusqu'à 40°C
- ◆ Profondeur d'immersion maximale : 5 m
- ◆ Passage solide $\leq 0.2\text{mm}$, Longueur câble : 8m

- ◆ Температура воды: до 40°C
- ◆ Максимальная глубина погружения: 5 м
- ◆ Сплошной проход $\leq 0.2\text{мм}$, Длина кабеля: 8м

MODEL CODE/CÓDIGO MODELO/ CODE MODÈLE/ КОД МОДЕЛИ

QDX (S) 3 - 32 - 1.1 F (T)

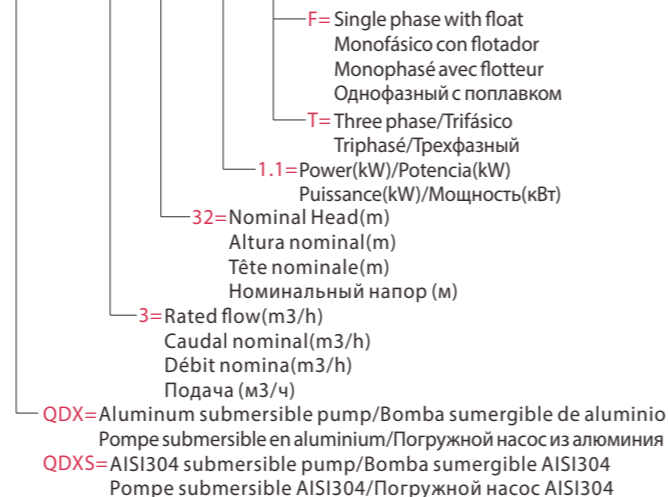

TECHNICAL DATA/DATOS TÉCNICOS/DONNÉES TECHNIQUES/ТЕХНИЧЕСКИЕ ДАННЫЕ

60Hz n≈3500l/min

MODEL MODELO MODÈLE МОДЕЛЬ	DN mm	Power Potencia Puissance Мощность kw hp	mm	Q=Delivery/Caudal/Débit/Подача													
				GPM 0 m³/h 0 l/min 0	6.6 1.5 25	13.2 3 50	23.8 5.4 90	29.1 6.6 110	37.0 8.4 140	39.6 9 200	52.9 12 230	60.8 13.8 245	64.8 14.7 270	71.4 16.2 290	76.7 17.4		
1ph with float	3ph			H=Head(m)/Altura(m)/Hauteur(m)/Общий напор в метрах водяного столба (м)													
QDX1.5-12-0.25F	QDX1.5-12-0.25T	25	0.25 0.33	≤0.2	13.2	11.3	8.5	3.7	-	-	-	-	-	-	-	-	-
QDX1.5-16-0.37F	QDX1.5-16-0.37T	25	0.37 0.5	≤0.2	16.8	15.5	13.5	9	6	-	-	-	-	-	-	-	-
QDX6-10-0.37F	QDX6-10-0.37T	40	0.37 0.5	≤0.2	11.6	11.5	11	10.1	9.2	7.6	7	3.3	-	-	-	-	-
QDX1.5-25-0.55F	QDX1.5-25-0.55T	25	0.55 0.75	≤0.2	26.5	25	22.5	15	8.8	-	-	-	-	-	-	-	-
QDX3-20-0.55F	QDX3-20-0.55T	25	0.55 0.75	≤0.2	21	21	20	17.5	15.5	11.5	10	-	-	-	-	-	-
QDX10-10-0.55F	QDX10-10-0.55T	40	0.55 0.75	≤0.2	14	14	14	13	12	10.3	9.8	5.2	2	-	-	-	-
QDX1.5-32-0.75F	QDX1.5-32-0.75T	25	0.75 1	≤0.2	35	32	28.5	22	17.5	10	-	-	-	-	-	-	-
QDX7-18-0.75F	QDX7-18-0.75T	40	0.75 1	≤0.2	21.5	21	20.6	19.5	19	17.8	17.2	15	13.5	12.5	11	10	-
QDX3-32-1.1F	QDX3-32-1.1T	25	1.1 1.5	≤0.2	35	34.6	32.5	26.5	22	13.5	11	-	-	-	-	-	-
QDX6-26-1.1F	QDX6-26-1.1T	40	1.1 1.5	≤0.2	28	28	27.7	26.2	25	22	21	14	7.5	4	-	-	-
QDX6-33-1.5F	QDX6-33-1.5T	40	1.5 2	≤0.2	36	36	35.2	34	32	29.2	28	21.3	16	12.5	6.5	-	-

MODEL MODELO MODÈLE МОДЕЛЬ	DN mm	Power Potencia Puissance Мощность kw hp	mm	mm	Q=Delivery/Caudal/Débit/Подача													
					GPM 0 m³/h 0 l/min 0	26 6 100	53 12 200	66 15 250	93 21 350	106 24 400	137 31.2 520	159 36 600	185 42 700	238 54 900	254 57.6 960	317 72 1200		
1ph with float	3ph				H=Head(m)/Altura(m)/Hauteur(m)/Общий напор в метрах водяного столба (м)													
QDX10-16-0.75F	QDX10-16-0.75T	50	0.75 1	≤0.2	19	18	14.4	11.5	3.8	-	-	-	-	-	-	-	-	
QDX15-10-0.75F	QDX15-10-0.75T	65	0.75 1	≤0.2	13.8	13.5	11.7	10.3	6.2	4	-	-	-	-	-	-	-	
QDX30-6-0.75F	QDX30-6-0.75T	80	0.75 1	≤0.2	8.3	8	7.8	7.5	7	6.6	5.5	4.5	3	-	-	-	-	
QDX14-16-1.1F	QDX14-16-1.1T	50	1.1 1.5	≤0.2	17.5	17.5	16.1	15	11.5	9.3	-	-	-	-	-	-	-	
QDX15-15-1.1F	QDX15-15-1.1T	65	1.1 1.5	≤0.2	17.5	17.5	16.1	15	11.5	9.3	-	-	-	-	-	-	-	
QDX40-7-1.1F	QDX40-7-1.1T	80	1.1 1.5	≤0.2	11.4	11.2	11	10.7	10.2	9.8	8.8	8	7.7	3.5	-	-	-	
QDX15-18-1.5F	QDX15-18-1.5T	65/50	1.5 2	≤0.2	19.5	18.7	17.5	16.6	14	12.2	6.5	-	-	-	-	-	-	
QDX40-9-1.5F	QDX40-9-1.5T	80	1.5 2	≤0.2	12	12	12.1	12	11.8	11.6	10.8	10	8.7	5	3.7	-	-	
QDX60-7-2.2F	QDX60-7-2.2T	100	2.2 3	≤0.2	10.7	10.7	10.7	10.7	10.5	10.3	10	9.7	9	7.7	7.2	4.8	-	

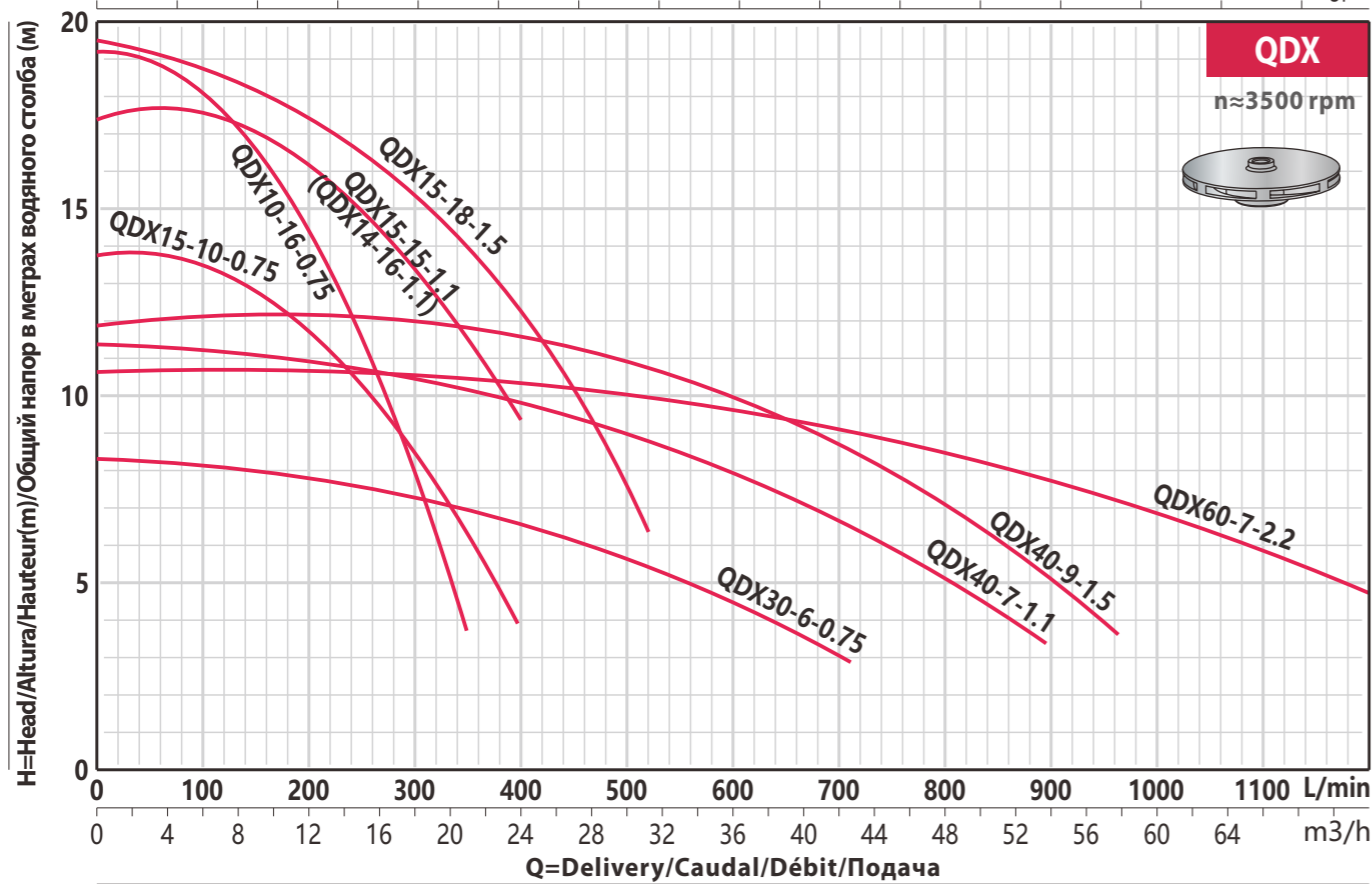
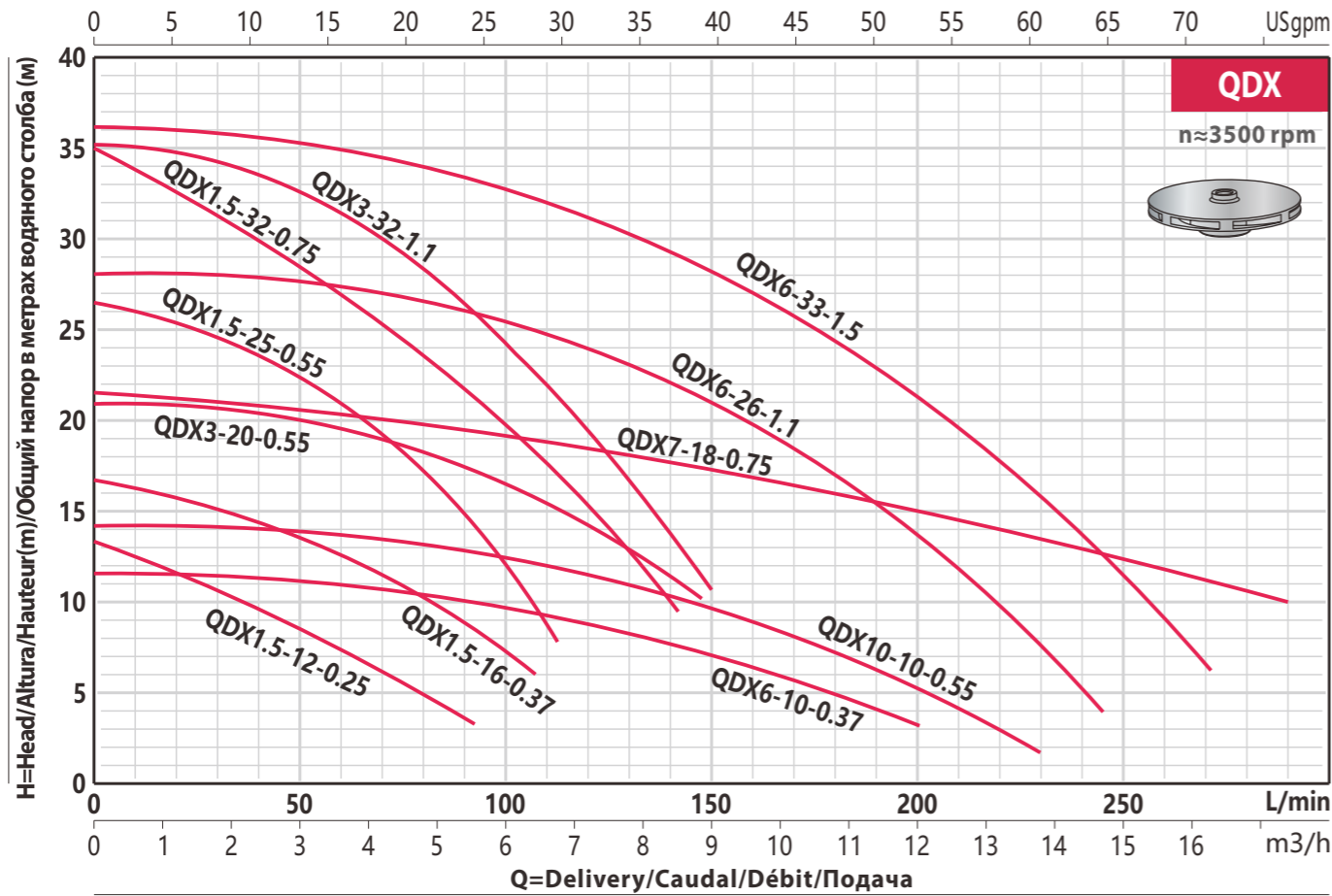

MATERIAL/MATERIAL/MATÉRIEL/MATERIAL

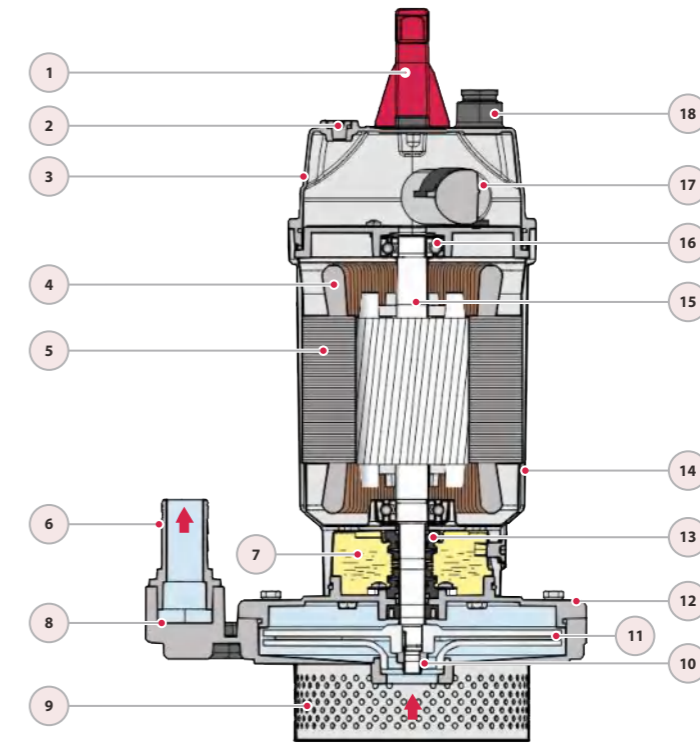

No.	Description/Descripción Description/Описание	Material/Material Matériel/Material
1	Handle/Manejar Poignée/Ручка	QDX: Plastic/Plástico QDXS: SUS304/Inox304 Plastique/Пластик Inox304/СУС304
2	Float switch port/Puerto de flotador Port de flotteur/Плавающий порт	/
3	Motor cover/Tapa de motor Capot moteur/Крышка мотора	QDX: Aluminum/Aluminio QDXS: SUS304/Inox304 Aluminium/Алюминий Inox304/СУС304
4	Wiring/Alambrado Câblage/Проводка	Copper/Cobre Cuivre/Медь
5	Stator/Estator Stator/Статор	Silicon/Silicio Silicium/Кремниевая
6	Output/salida Sortie/Выходной	Aluminum/Aluminio Aluminium/Алюминий
7	Chamber/Sala Chambre/Камера	Aluminum/Aluminio Aluminium/Алюминий
8	Pump Case/Cuerpo de Bomba Boitier pompe/Корпус насоса	Cast iron/Fundición Fonte/Чугун
9	Strainer/Colador Passoire/Ситечко	SUS304/Inox304 Inox304/СУС304

No.	Description/Descripción Description/Описание	Material/Material Matériel/Material
10	Impeller nut/Tuerca del impulsor Écrou de roue/Гайка крыльчатки	SUS304/Inox304 Inox304/СУС304
11	Impeller/Impulsor Roue/Импелсор	QDX: Aluminum/Aluminio QDXS: Plastic/Plástico Aluminium/Алюминий Plastique/Пластик
12	Seal plate/Plato sello Plaque/Уплотнительная пластина	Cast iron/Fundición Fonte/Чугун
13	Mechanical Seal/Cierre Mecánico Garniture/Механическая печать	SiC-SiC/SiC-SiC SiC-SiC/SiC-SiC
14	Motor Case/Cuerpo Motor Boitier moteur/Мотор Корпус	QDX: Aluminum/Aluminio QDXS: SUS304/Inox304 Aluminium/Алюминий Inox304/СУС304
15	Shaft/Eje Arbre/Вал	SUS304/Inox304 Inox304/СУС304
16	Bearing/Cojinete Palier/Подшипник	Ball Bearing/Bola Rodamiento Palier Balle/шарикоподшипник
17	Capacitor/Condensador Condensateur/Конденсатор	Assembly/Asamblea Assemblée/Ассамблея
18	Cable port/Puerto de cables Port de câble/Кабельный порт	/