

SUP

n≈2900/1450rpm

Swimming pool pump
Bomba de piscina
Pompe de piscine
Насос для бассейна



FEATURE/RASGO/FONCTIONNALITÉ/ОСОБЕННОСТЬ

European type with max suction 1.5m
Tipo europeo con succión máxima de 1,5 m
Type européen avec aspiration maximale 1,5 m
Европейский тип с максимальной высотой всасывания 1,5 м

APPLICATIONS/APLICACIONES/APPLICATIONS/ПРИЛОЖЕНИЯ

- Suitable for mariculture circulation filter and recirculation of water in swimming pool equipment.
- Indicado para filtro de circulación de maricultura y recirculación de agua en equipos de piscinas.
- Convient pour le filtre de circulation de mariculture et la recirculation de l'eau dans les équipements de piscine.
- Подходит для циркуляционного фильтра марикультуры и рециркуляции воды в оборудовании для бассейнов.

DIMENSIONS AND N.W./DIMENSIONES Y PESOS/DIMENSIONS ET POIDS/РАЗМЕРЫ И ВЕС

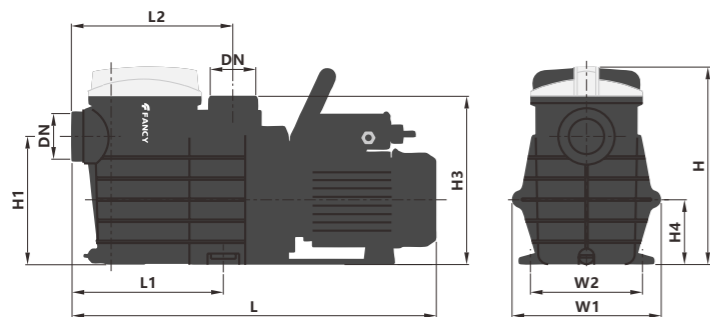

MODEL MODELO MODÈLE МОДЕЛЬ	DIMENSIONS/DIMENSIONES/DIMENSIONS/РАЗМЕРЫ mm									GW Kg
	L	L1	L2	W1	W2	H	H1	H3	H4	
SUPB100	593	254	264	240	194	320	207	272	105	16
SUPB150	593	254	264	240	194	320	207	272	105	17.3
SUPB200	593	254	264	240	194	320	207	272	105	19
SUPB250	593	254	264	240	194	320	207	272	105	20.8
SUPB300	609	254	264	240	194	320	207	272	105	22.3
SUPA150	628	254	264	240	194	320	207	272	105	19.3
SUPA200	628	254	264	240	194	320	207	272	105	21
SUPA250	628	254	264	240	194	320	207	272	105	23
SUPA300	628	254	264	240	194	320	207	272	105	24.1
SUPA200-II	646	254	264	240	194	320	207	272	105	22
SUPA250-II	646	254	264	240	194	320	207	272	105	24
SUPA300-II	646	254	264	240	194	320	207	272	105	24.8

USING/UTILIZACIÓN/UTILISATION/ИСПОЛЬЗОВАНИЕ

- Liquid temperature between +5°C and +50°C
- Ambient temperature between 0°C and +50°C
- Max. working pressure 3 bar. IP55, F
- Temperatura del líquido de +5 °C hasta +50 °C
- Temperatura ambiente de 0 °C hasta +50 °C
- Presión máxima en el cuerpo de la bomba 3 bar. IP55, F
- Température du liquide entre +5 °C et +50 °C
- Température ambiante entre 0 °C et +50 °C
- Max. pression de service 3 bar. IP55, F
- Температура жидкости от +5°C до +50°C
- Температура окружающей среды от 0°C до +50°C
- Макс. рабочее давление 3 бар. IP55, F

FANCY

TECHNICAL DATA/DATOS TÉCNICOS/DONNÉES TECHNIQUES/ТЕХНИЧЕСКИЕ ДАННЫЕ

50Hz n≈2900/1450l/min

MODEL MODELO MODÈLE МОДЕЛЬ	1-ph	rpm	DN inch	Power Potencia Puissance Мощность P1 kw hp	Q=Delivery/Caudal/Débit/Подача													
					GPM 0	26	40	53	57	61	66	82	90	111	123	127	143	
					m ³ /h 0	6	9	12	12.9	13.8	15	18.6	20.4	25.2	27.9	28.8	32.4	
					l/min 0	100	150	200	215	230	250	310	340	420	465	480	540	
					H=Head(m)/Altura(m)/Hauteur(m)/Общий напор в метрах водяного столба (м)													
SUPB100	2900	2FBTx2FBT	0.75	1	14.5	12.5	11.2	10	9.3	9	8.2	6	5	-	-	-	-	
SUPB150	2900	2FBTx2FBT	1.1	1.5	17	16	15	14	13.3	13	12.5	10.5	9.5	5.3	-	-	-	
SUPB200	2900	2FBTx2FBT	1.5	2	19	17.5	17.5	16.7	16.5	16	15.5	14	13	10	8	-	-	
SUPB250	2900	2FBTx2FBT	1.85	2.5	21	20.5	20	19	19	18.5	18.1	16.7	16	13	11	10	-	
SUPB300	2900	2FBTx2FBT	2.2	3	23	22.5	22	21	21	20.7	20.3	19	18.5	16	14.5	14	11.7	
SUPA150	2900	2FBTx2FBT	1.1	1.5	17	16	15	14	13.3	13	12.5	10.5	9.5	5.3	-	-	-	
SUPA200	2900	2FBTx2FBT	1.5	2	19	17.5	17.5	16.7	16.5	16	15.5	14	13	10	8	-	-	
SUPA250	2900	2FBTx2FBT	1.85	2.5	21	20.5	20	19	19	18.5	18.1	16.7	16	13	11	10	-	
SUPA300	2900	2FBTx2FBT	2.2	3	23	22.5	22	21	21	20.7	20.3	19	18.5	16	14.5	14	11.7	
SUPA200-II	1450	2FBTx2FBT	0.35	0.47	4	3.5	3	2	1.9	-	-	-	-	-	-	-	-	
SUPA200-II	2900	2FBTx2FBT	1.5	2	19	17.5	17.5	16.7	16.5	16	15.5	14	13	10	8	-	-	
SUPA250-II	1450	2FBTx2FBT	0.4	0.55	5	4.5	4	3.2	3	2.5	2	-	-	-	-	-	-	
SUPA250-II	2900	2FBTx2FBT	1.85	2.5	21	20.5	20	19	19	18.5	18.1	16.7	16	13	11	10	-	
SUPA300-II	1450	2FBTx2FBT	0.45	0.6	5.5	4.5	3.8	2.8	2.6	2	1.5	-	-	-	-	-	-	
SUPA300-II	2900	2FBTx2FBT	2.2	3	23	22.5	22	21	21	20.7	20.3	19	18.5	16	14.5	14	11.7	

PERFORMANCE CURVE/CURVA DE RENDIMIENTO/COURBE DE PERFORMANCE/КРИВАЯ ПРОИЗВОДИТЕЛЬНОСТИ

